



fontanot®
scale di ogni tempo



<http://www.fontanot.it>
<http://www.arkestairs.com>

Copyright by Fontanot S.p.A., first publication August 3, 2015

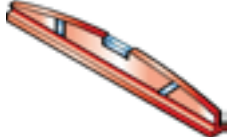

PH 2



Ø 8 x 120 mm
(D 5/16" x 4 23/32")
Ø 12 x 120 mm
(D 15/32" x 4 23/32")
Ø 14 x 150 mm
(D 35/64" x 5 29/32")



Ø 2,5mm (D 3/32")
Ø 3,5mm (D 9/64")
Ø 4,5mm (D 11/64")
Ø 5,5mm (D 7/32")
Ø 9mm (D 23/64")



12 mm (15/32")
13 mm (33/64")



2,5 mm (3/32")
3 mm (1/8")
5 mm (13/64")
12 mm (15/32")



10 mm (25/64")
13 mm (33/64")
17 mm (43/64")
19 mm (3/4")
30 mm (1 3/16")



1

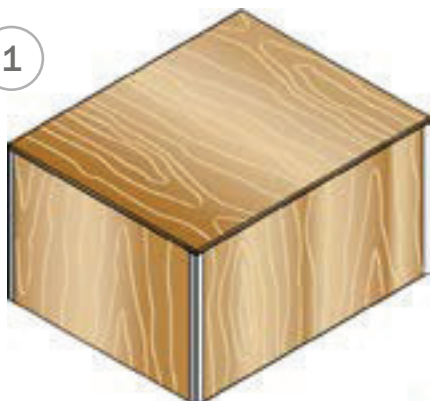

2

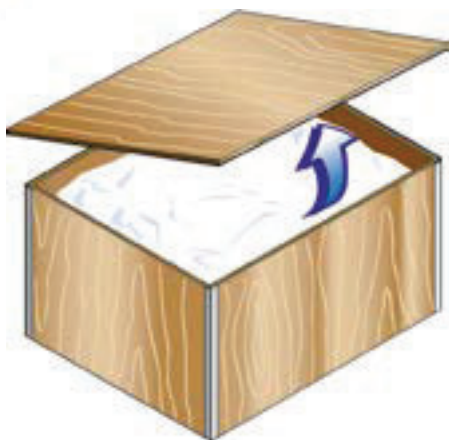

3



10	11	12	13	14	15	16
1	1	2	2	4	5	6

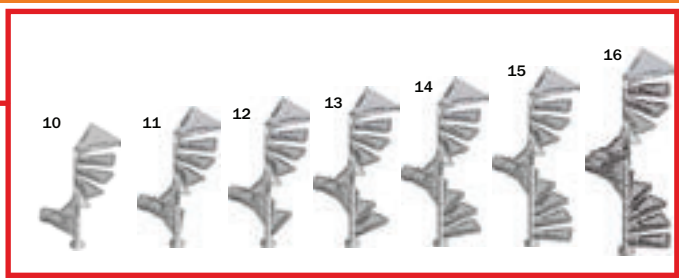
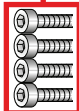

<p>Ø 120 cm (D 47 1/4")</p> <p>"A"</p>	<p>Ø 140 cm (D 55 1/8")</p> <p>"B"</p>	<p>Ø 160 cm (D 63")</p> <p>"C"</p>
--	--	--

A02

	10	11	12	13	14	15	16
A	1	1	1	1	1	1	1
B	1	1	1	1	1	1	1
C	1	1	1	1	1	1	1

A03

	10	11	12	13	14	15	16
A	6	6	6	6	6	6	6
B	6	6	6	6	6	6	6
C	6	6	6	6	6	6	6

A18

	10	11	12	13	14	15	16
A	1	1	1	1	1	1	1
B	1	1	1	1	1	1	1
C	1	1	1	1	1	1	1

A19

	10	11	12	13	14	15	16
A	1	1	1	1	1	1	1
B	1	1	1	1	1	1	1
C	1	1	1	1	1	1	1

B03

	10	11	12	13	14	15	16
A	1	1	1	1	1	1	1
B	1	1	1	1	1	1	1
C	1	1	1	1	1	1	1

B04

	10	11	12	13	14	15	16
A	1	1	1	1	1	1	1
B	1	1	1	1	1	1	1
C	1	1	1	1	1	1	1

B05

	10	11	12	13	14	15	16
A	1	1	1	1	1	1	1
B	1	1	1	1	1	1	1
C	1	1	1	1	1	1	1

B08

	10	11	12	13	14	15	16
A	2	2	2	2	2	2	2
B	2	2	2	2	2	2	2
C	2	2	2	2	2	2	2

B11

	10	11	12	13	14	15	16
A	7	7	7	7	7	7	7
B	10	10	10	10	10	10	10
C	10	10	10	10	10	10	10

B12

	10	11	12	13	14	15	16
A	7	7	7	7	7	7	7
B	10	10	10	10	10	10	10
C	10	10	10	10	10	10	10

B13

	10	11	12	13	14	15	16
A	6	6	6	6	6	6	6
B	6	6	6	6	6	6	6
C	6	6	6	6	6	6	6

B17

	10	11	12	13	14	15	16
A	1	1	1	1	1	1	1
B	1	1	1	1	1	1	1
C	1	1	1	1	1	1	1

B23

	10	11	12	13	14	15	16
A	6	6	6	6	6	6	6
B	7	7	7	7	7	7	7
C	8	8	8	8	8	8	8

B27

	10	11	12	13	14	15	16
A	12	12	12	12	12	12	12
B	14	14	14	14	14	14	14
C	16	16	16	16	16	16	16

B36

	10	11	12	13	14	15	16
A	2	2	2	2	2	2	2
B	3	3	3	3	3	3	3
C	3	3	3	3	3	3	3

B37

	10	11	12	13	14	15	16
A	2	2	2	2	2	2	2
B	3	3	3	3	3	3	3
C	3	3	3	3	3	3	3

B46

	10	11	12	13	14	15	16
A	2	2	2	2	2	2	2
B	2	2	2	2	2	2	2
C	2	2	2	2	2	2	2

B47

	10	11	12	13	14	15	16
A	1	1	1	1	1-2	2	2
B	1	1	1	1	1-2	2	2
C	1	1	1	1	1-2	2	2

B54

	10	11	12	13	14	15	16
A	27	29	31	33	35	37	39
B	37	40	43	46	49	52	55
C	38	41	44	47	50	53	56

B55

	10	11	12	13	14	15	16
A	27	29	31	33	35	37	39
B	37	40	43	46	49	52	55
C	38	41	44	47	50	53	56

B82

	10	11	12	13	14	15	16
A	19	21	23	25	27	29	31
B	28	31	34	37	40	43	46
C	28	31	34	37	40	43	46

B89

	10	11	12	13	14	15	16
A	6	6	6	6	6	6	6
B	7	7	7	7	7	7	7
C	8	8	8	8	8	8	8

BE3

	10	11	12	13	14	15	16
A	25	27	29	31	33	35	37
B	35	38	41	44	47	50	53
C	36	39	42	45	48	51	54

BE4

	10	11	12	13	14	15	16
A	1	1	1	1	1	1	1
B	1	1	1	1	1	1	1
C	1	1	1	1	1	1	1

BG6

	10	11	12	13	14	15	16
A	29	32	35	38	41	44	47
B	38	42	46	50	54	58	62
C	38	42	46	50	54	58	62

BS1

	10	11	12	13	14	15	16
A	1	1	1	1	1	1	1
B	1	1	1	1	1	1	1
C	1	1	1	1	1	1	1

C07 H = 935 mm
(36 13/16")

	10	11	12	13	14	15	16
A	7	7	7	7	7	7	7
B	8	8	8	8	8	8	8
C	9	9	9	9	9	9	9

C07 H = 1060 mm
(41 3/4")

	10	11	12	13	14	15	16
A	0	0	0	0	0	0	0
B	9	10	11	12	13	14	15
C	9	10	11	12	13	14	15

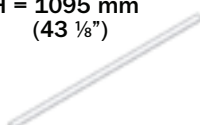
C07 H = 1095 mm
(43 1/8")

	10	11	12	13	14	15	16
A	9	10	11	12	13	14	15
B	0	0	0	0	0	0	0
C	0	0	0	0	0	0	0

C07 H = 1130 mm
(44 1/2")

	10	11	12	13	14	15	16
A	0	0	0	0	0	0	0
B	9	10	11	12	13	14	15
C	9	10	11	12	13	14	15

C07 H = 1190 mm
(46 7/8")

	10	11	12	13	14	15	16
A	9	10	11	12	13	14	15
B	9	10	11	12	13	14	15
C	9	10	11	12	13	14	15

C13

	10	11	12	13	14	15	16
A	29	32	35	38	41	44	47
B	38	42	46	50	54	58	62
C	38	42	46	50	54	58	62

C29

	10	11	12	13	14	15	16
A	6	6	6	6	6	6	6
B	9	9	9	9	9	9	9
C	9	9	9	9	9	9	9

C31

	10	11	12	13	14	15	16
A	37	40	43	46	49	52	55
B	47	51	55	59	63	67	71
C	48	52	56	60	64	68	72

C36

	10	11	12	13	14	15	16
A	1	1	1	1	1	1	1
B	1	1	1	1	1	1	1
C	1	1	1	1	1	1	1

C87

	10	11	12	13	14	15	16
A	4	4	4	4	4	4	4
B	4	4	4	4	4	4	4
C	4	4	4	4	4	4	4

C92

	10	11	12	13	14	15	16
A	2	2	2	2	2	2	2
B	2	2	2	2	2	2	2
C	2	2	2	2	2	2	2

CC5

	10	11	12	13	14	15	16
A	27	29	31	33	35	37	39
B	37	40	43	46	49	52	55
C	38	41	44	47	50	53	56

CC6

	10	11	12	13	14	15	16
A	27	29	31	33	35	37	39
B	37	40	43	46	49	52	55
C	38	41	44	47	50	53	56

CL7

	10	11	12	13	14	15	16
A	1	1	1	1	1	1	1
B	1	1	1	1	1	1	1
C	1	1	1	1	1	1	1

CL8

	10	11	12	13	14	15	16
A	1	1	1	1	1	1	1
B	1	1	1	1	1	1	1
C	1	1	1	1	1	1	1

D01

	10	11	12	13	14	15	16
A	3	3	4	3	3	3	3
B	3	3	4	3	3	3	3
C	3	3	4	3	3	3	3

D02

	10	11	12	13	14	15	16
A	10	11	12	13	14	15	16
B	10	11	12	13	14	15	16
C	10	11	12	13	14	15	16

D03

	10	11	12	13	14	15	16
A	50	55	60	65	70	75	80
B	50	55	60	65	70	75	80
C	50	55	60	65	70	75	80

D04

	10	11	12	13	14	15	16
A	9	10	11	12	13	14	15
B	9	10	11	12	13	14	15
C	9	10	11	12	13	14	15

D05

	10	11	12	13	14	15	16
A	1	1	1	1	1	1	1
B	1	1	1	1	1	1	1
C	0	0	0	0	0	0	0

D12

	10	11	12	13	14	15	16
A	0	0	0	0	0	0	0
B	0	0	0	0	0	0	0
C	1	1	1	1	1	1	1

D14

	10	11	12	13	14	15	16
A	1	1	1	1	1	1	1
B	1	1	1	1	1	1	1
C	1	1	1	1	1	1	1

D32

	10	11	12	13	14	15	16
A	29	32	35	38	41	44	47
B	38	42	46	50	54	58	62
C	38	42	46	50	54	58	62

D33

	10	11	12	13	14	15	16
A	29	32	35	38	41	44	47
B	38	42	46	50	54	58	62
C	38	42	46	50	54	58	62

E08

	10	11	12	13	14	15	16
A	1	1	1	1	1	1	1
B	1	1	1	1	1	1	1
C	1	1	1	1	1	1	1

F01



	10	11	12	13	14	15	16
A	8	8	8	8	8	8	8
B	9	9	9	9	9	9	9
C	10	10	10	10	10	10	10

F08



	10	11	12	13	14	15	16
A	4	4	4	4	4	4	4
B	6	6	6	6	6	6	6
C	6	6	6	6	6	6	6

F09



	10	11	12	13	14	15	16
A	2	2	2	2	2	2	2
B	3	3	3	3	3	3	3
C	3	3	3	3	3	3	3

G01



	10	11	12	13	14	15	16
A	1	1	1	1	1	1	1
B	1	1	1	1	1	1	1
C	1	1	1	1	1	1	1

G02



	10	11	12	13	14	15	16
A	2	2	2	2	2-3	3	3
B	2	2	2	2	2-3	3	3
C	2	2	2	2	2-3	3	3

G03



	10	11	12	13	14	15	16
A	1	1	1	1	1	1	1
B	1	1	1	1	1	1	1
C	1	1	1	1	1	1	1

L65

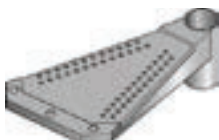

	10	11	12	13	14	15	16
A	9	10	11	12	13	14	15
B	0	0	0	0	0	0	0
C	0	0	0	0	0	0	0

L65

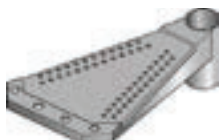

	10	11	12	13	14	15	16
A	0	0	0	0	0	0	0
B	9	10	11	12	13	14	15
C	9	10	11	12	13	14	15

X01



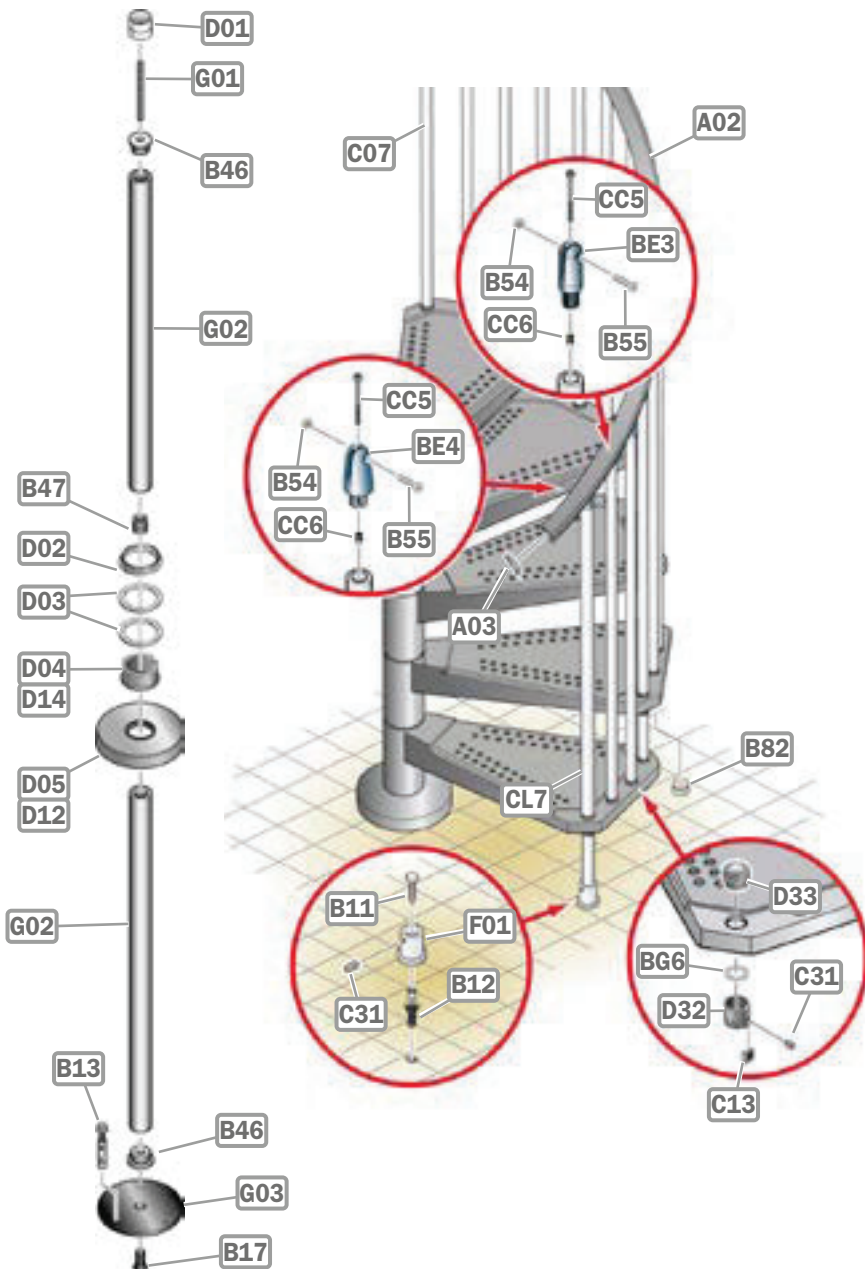

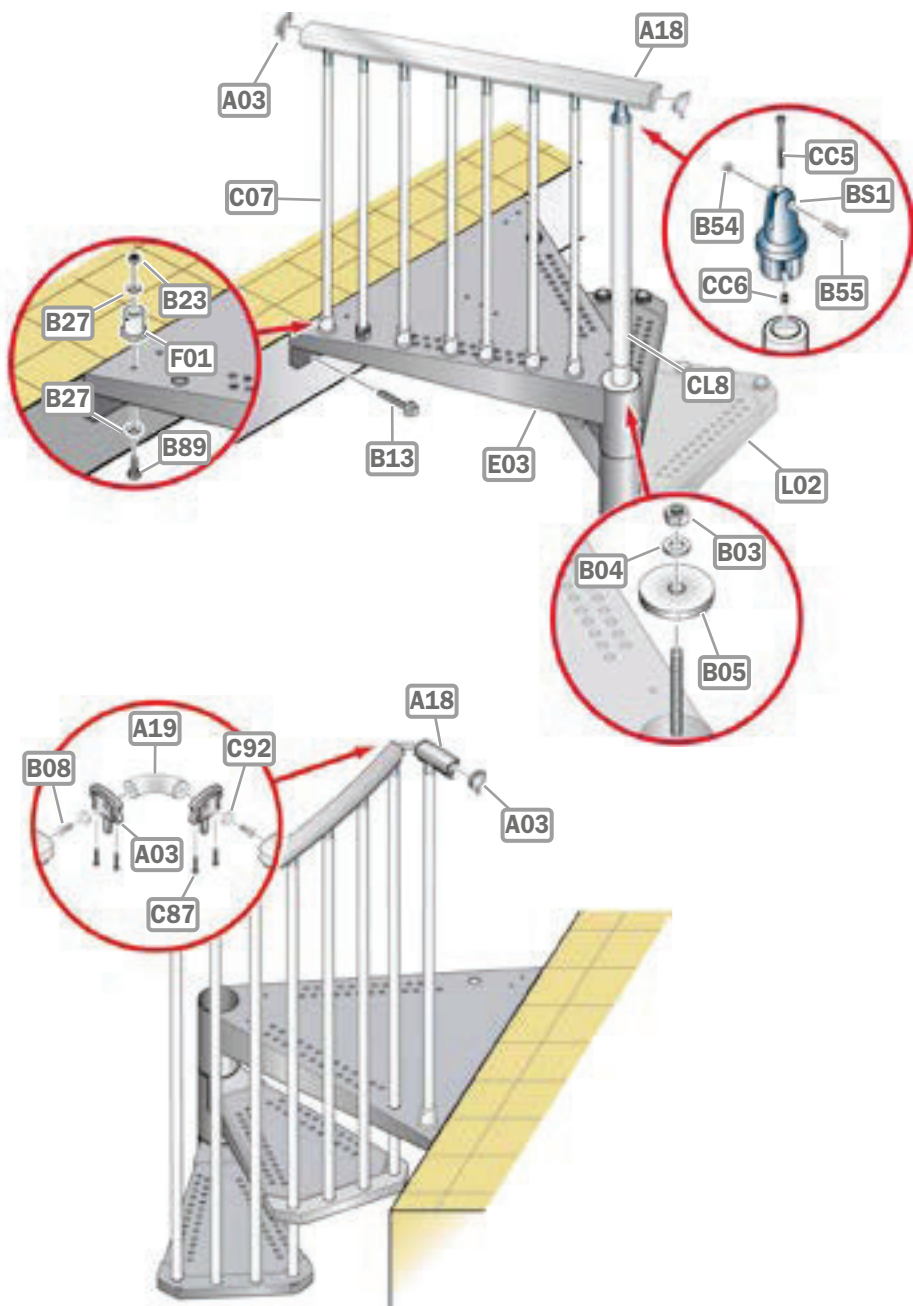

IT)



**IMPORTANTE!
LEGGERE E SEGUIRE SCRUPOLOSAMENTE QUESTE ISTRUZIONI E TENERE PER
FUTURE CONSULTAZIONI**

ATTENZIONE: eseguire l'installazione "a regola d'arte", utilizzando attrezzi idonei; seguire scrupolosamente le istruzioni di montaggio. Informarsi prima dell'installazione, sui regolamenti locali e nazionali da rispettare, in funzione della destinazione d'uso (privato principale, secondario, uffici, negozi,...).

EN)



**IMPORTANT!
CAREFULLY READ AND STRICTLY FOLLOW THESE INSTRUCTIONS AND KEEP
THEM FOR FUTURE CONSULTATION**

WARNING: Carry out the installation in a "workmanlike" manner, strictly following the installation instructions and using suitable tools. Always consult your local building department for code requirements that must be respected depending on its destination of use (private, secondary, public,...)

DE)



**WICHTIG!
LESEN SIE DIESE ANLEITUNG SORGFÄLTIG DURCH UND HEBEN SIE SIE FÜR
SPÄTERE ZWECKE AUF**

ACHTUNG: Die Montage muss fachgerecht, unter Zuhilfenahme geeigneter Hilfsmittel und unter strikter Einhaltung der Montageanleitung ausgeführt werden. Damit die Montage normgerecht erfolgen kann, muss man zuvor Informationen zur Aufstellung und zu den lokal und national geltenden Vorschriften je nach Bestimmungszweck (privat, Haupt- oder Nebeneinrichtung, Büros, Geschäfte, ...) einholen.

FR)



**IMPORTANT !
LIRE ET RESPECTER SCRUPULEUSEMENT LES PRÉSENTES INSTRUCTIONS ;
LES CONSERVER POUR TOUTE AUTRE CONSULTATION**

ATTENTION : Effectuer l'installation dans les règles de l'art en utilisant des outils appropriés ; suivre scrupuleusement les instructions de montage. Pour réaliser un montage conforme aux normes en vigueur, il faut s'informer avant l'installation quant aux réglementations locales et nationales à respecter, en fonction du domaine d'utilisation (résidence privée principale, secondaire, bureaux, magasins,...).

ES)



**¡IMPORTANTE!
LEER Y SEGUIR EstrictAMENTE ESTAS INSTRUCCIONES Y CONSERVARLAS
PARA CONSULTAS FUTURAS**

ATENCIÓN: realizar la instalación "según las reglas del arte", utilizando herramientas adecuadas; seguir estrictamente las instrucciones de montaje. Informarse antes de la instalación sobre los reglamentos locales y nacionales a respetar, en función del destino de uso (privado principal, secundario, oficinas, tiendas,...).

PT)  **IMPORTANT!
CAREFULLY READ AND STRICTLY FOLLOW THESE INSTRUCTIONS AND KEEP
THEM FOR FUTURE CONSULTATION**

ATENÇÃO: efetuar a instalação de acordo com as regras usando ferramentas adequada; seguir escrupulosamente as instruções de montagem. Informar-se antes da instalação sobre os regulamentos locais e nacionais a respeitar, em função do destino de uso (privado principal, secundário, escritórios, lojas, etc.).

NL)  **BELANGRIJK!
DEZE VOORSCHRIFTEN ZORGVULDIG DOORLEZEN EN OPVOLGEN EN BEWAREN
VOOR LATERE RAADPLEGING**

OPGELET: verricht de installatie volgens de technische normen met behulp van geschikte gereedschappen; volg nauwgezet de montage handleiding. Ga voor de installatie na of er plaatselijk of nationaal regelgeving van toepassing is voor het bedoelde gebruik (privé, kantoor, winkels, enz.).

PL)  **IMPORTANT!
CAREFULLY READ AND STRICTLY FOLLOW THESE INSTRUCTIONS AND KEEP
THEM FOR FUTURE CONSULTATION**

UWAGA: wykonać montaż „zgodnie z zasadami sztuki“, przy użyciu odpowiednich narzędzi; skrupulatnie przestrzegać instrukcji montażowej. Przed dokonaniem montażu, uzyskać informacje na temat miejscowych i krajowych przepisów, jakich należy przestrzegać w zależności od przeznaczenia (głównie prywatne, drugorzędne, biura, sklepy ...).

HU)  **IMPORTANT!
CAREFULLY READ AND STRICTLY FOLLOW THESE INSTRUCTIONS AND KEEP
THEM FOR FUTURE CONSULTATION**

FIGYELEM! A telepítést szakszerűen végezze el, szigorúan betartva a telepítési útmutatót és megfelelő szerszámokat használva. Mindig kérje ki a helyi építésügyi hatóságoktól a hatályos előírásokat, melyeket a célterülettel (privát, helyiérdekű, nyilvános stb.) be kell tartani.

RO)  **IMPORTANT!
CAREFULLY READ AND STRICTLY FOLLOW THESE INSTRUCTIONS AND KEEP
THEM FOR FUTURE CONSULTATION**

ATENȚIE: efectuați instalarea conform regulilor de bună practică utilizând unelte adecvate; respectați strict instrucțiunile de montaj. Înainte de instalare, informați-vă cu privire la reglementările locale și naționale care trebuie să fie respectate, în funcție de destinația folosirii (privat principal, secundar, birouri, magazine...).

RU)



IMPORTANT!
CAREFULLY READ AND STRICTLY FOLLOW THESE INSTRUCTIONS AND KEEP THEM FOR FUTURE CONSULTATION

ВНИМАНИЕ: выполните монтаж по правилам мастерства, используя подходящие инструменты; строго следуйте инструкциям по монтажу. Перед монтажом узнайте о местных и национальных нормативах, которые требуется соблюдать, в зависимости от назначения изделия (основное частное, вторичное, офисы, магазины и т.п.).

HR)



IMPORTANT!
CAREFULLY READ AND STRICTLY FOLLOW THESE INSTRUCTIONS AND KEEP THEM FOR FUTURE CONSULTATION

POZOR: postavljanje izvršite prema pravilima struke, služeći se prikladnim alatima; strogo slijedite upute za montažu. Prije postavljanja informirajte se o lokalnim i državnim odredbama koje treba poštovati ovisno o namjeni (glavna ili sporedna privatna uporaba, uredi, trgovine...).

SR)



IMPORTANT!
CAREFULLY READ AND STRICTLY FOLLOW THESE INSTRUCTIONS AND KEEP THEM FOR FUTURE CONSULTATION

UPOZORENJE: Izvršite instaliranje po svim pravilima, strogo se pridržavajte uputstava o instalaciji i koristite odgovarajući alat. Uvek konsultujte Vaše lokalno građevinsko odeljenje u vezi sa zahtevima propisa koji se moraju poštovati u zavisnosti od njihove namene (privatni, sekundarni, javni...).

CS)



IMPORTANT!
CAREFULLY READ AND STRICTLY FOLLOW THESE INSTRUCTIONS AND KEEP THEM FOR FUTURE CONSULTATION

POZOR: Proved'te instalaci „odborným“ způsobem a přesně dodržujte pokyny pro instalaci a používejte vhodné nástroje. Vždy si zjistěte na místním stavebním úřadě, jaké jsou požadavky předpisů, které musí být dodržovány v závislosti na určeném použití (soukromý, druhotný, veřejný...)

SK)



IMPORTANT!
CAREFULLY READ AND STRICTLY FOLLOW THESE INSTRUCTIONS AND KEEP THEM FOR FUTURE CONSULTATION

VAROVANIE: Inštaláciu vykonajte profesionálnym spôsobom, striktne dodržiavajte nasledovné inštaláčne inštrukcie a použite vhodné nástroje. V prípade požiadavok kódov, ktoré sa musia dodržať v závislosti od miesta použitia (súkromné priestory, pomocné priestory, verejné priestory...) to vždy konzultujte so svojim miestnym stavebným oddelením.

SL)  **IMPORTANT!
CAREFULLY READ AND STRICTLY FOLLOW THESE INSTRUCTIONS AND KEEP
THEM FOR FUTURE CONSULTATION**

POZOR: nameštitev izvedite po “pravilih stroke” z ustreznim orodjem; strogo upoštevajte navodila za nameštitev. Pred namestitvijo se pozanimajte glede lokalnih in nacionalnih zakonskih standardov glede na namembnost uporabe (zasebna, poslovna, v pisarni, trgovini...).

DA)  **VIGTIGT!
LÆS OG FØLG DENNE ANVISNING NØJE, OG GEM DEN TIL SENERE BRUG**

ADVARSEL: Installationen skal udføres i overensstemmelse med bedste praksis, ved brug af egnede redskaber; følg omhyggeligt monteringsinstruktionerne. Hent oplysninger før installationen angående de lokale og nationale bestemmelser, der skal overholdes afhængigt af den påtænkte anvendelse (privat hovedbrug, privat sekundær brug, kontorer, butikker,...).

SV)  **VIKTIG INFORMATION!
LÅS OCH FÖLJ DESSA INSTRUKTIONER NOGGRANT OCH SPARA DEM FÖR
FRAMTIDA BRUK**

OBSERVERA! Utför installationen på ett yrkesmannamässigt sätt med lämpliga verktyg. Följ monteringsinstruktionerna i detalj. Informera dig före installationen om lokala och nationella bestämmelser som ska respekteras, beroende på avsett användningsområde (privat, offentlig, kontor, butiker o.s.v.).

FI)  **TÄRKEÄÄ!
LUE NÄMÄ OHJEET HUOLELLISESTI JA NOUDATA NIITÄ. SÄILYTÄ NE
MYÖHEMPÄÄ TARVETTA VARTEN.**

VAROITUS: suorita asennus kunnolla käyttäen asianmukaisia välineitä; noudata huolellisesti asennusohjeita. Tutustu ennen asennusta voimassa oleviin paikallisiin ja kansallisiin määräyksiin, käyttökohteen mukaan (yksityinen pääasiallinen, toissijainen, toimisto, kaupat,...).

ET)  **IMPORTANT!
CAREFULLY READ AND STRICTLY FOLLOW THESE INSTRUCTIONS AND KEEP
THEM FOR FUTURE CONSULTATION**

HOIATUS: Paigaldage seade vastavalt headele tavadele, järgides täpselt paigaldusjuhiseid ja kasutades sobivaid tööriistu. Konsulteerige kindlasti kohaliku ehitusosakonnaga, kust saate täpselt teavet nõuete kohta, mida olenevalt seadme kasutusotstarbest tuleb kindlasti täita (erakasutus, sekundaarne, avalik jne)

TR)



**IMPORTANT!
CAREFULLY READ AND STRICTLY FOLLOW THESE INSTRUCTIONS AND KEEP
THEM FOR FUTURE CONSULTATION**

UYARI: Kurulum talimatlarını tam anlamıyla takip ederek ve uygun aletler kullanarak, “ustalıkla” kurulum işlemini yerine getirin. Kullanım amacına göre (özel, ikincil, kamusal...) riayet edilmesi gereken kod gereklilikleri için yerel inşaat departmanınıza danışın.

NO)



**VIKTIG!
LES OG FØLG DISSE ANVISNINGENE OMHYGGELIG OG OPPBEVAR DEM FOR
SENERE REFERANSE.**

ADVARSEL: Produktet må installeres ”etter alle kunstens regler” og med passende verktøy. Følg monteringsbeskrivelsen nøye. Informer deg om eventuelle lokale og nasjonale forskrifter som gjelder for ditt spesielle bruksområde (primær eller sekundær privat bruk, kontorer, forretninger osv.) før du installerer produktet.

KO)



**IMPORTANT!
CAREFULLY READ AND STRICTLY FOLLOW THESE INSTRUCTIONS AND KEEP
THEM FOR FUTURE CONSULTATION**

경고: 설치 지침을 성실하게 따르면서 적절한 도구를 사용하여 설치를 실행하십시오. 사용 목적(개인, 보조, 공용 등)에 따라 항상 현지 건설부의 규정을 준수해야 합니다.

4

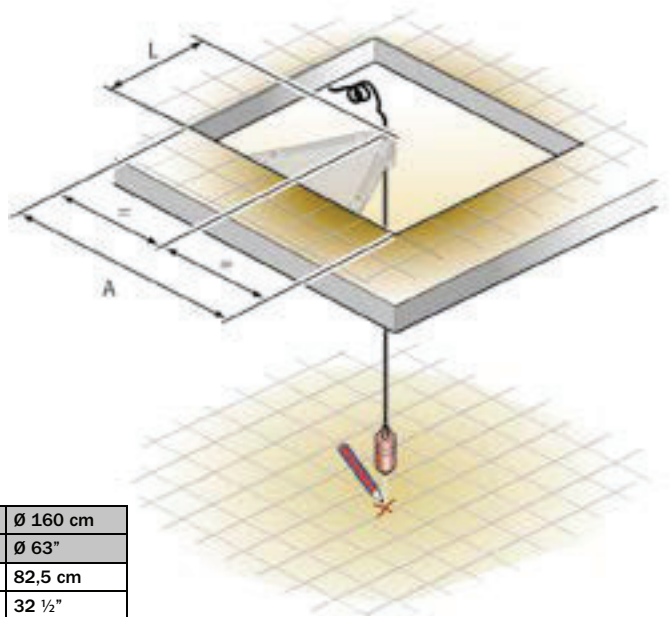

	Ø 120 cm	Ø 140 cm	Ø 160 cm
	Ø 47 1/4"	Ø 55 1/8"	Ø 63"
L	62,5 cm	72,5 cm	82,5 cm
L	24 3/8"	28 3/16"	32 1/2"

5

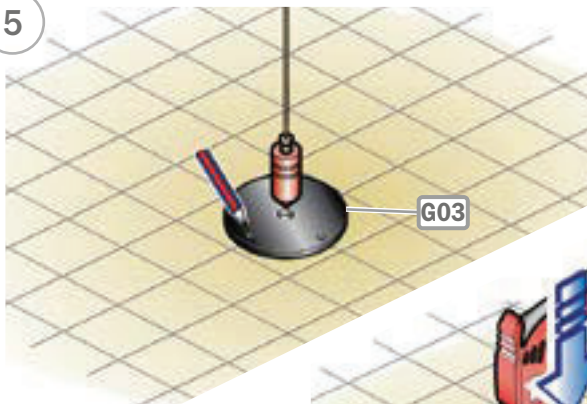

6

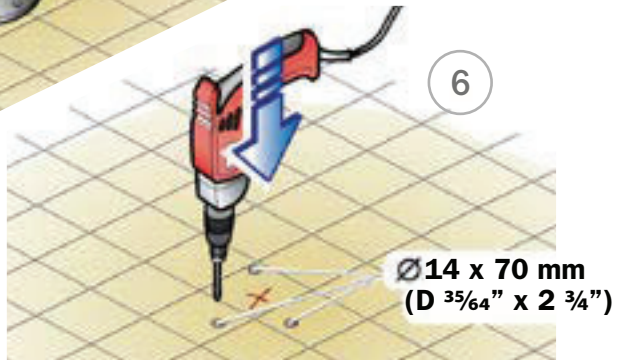

Ø 14 x 70 mm
(D 35/64" x 2 3/4")

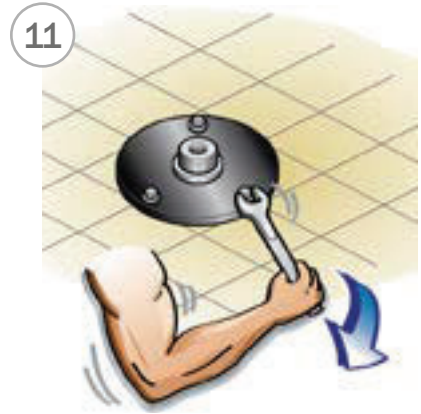
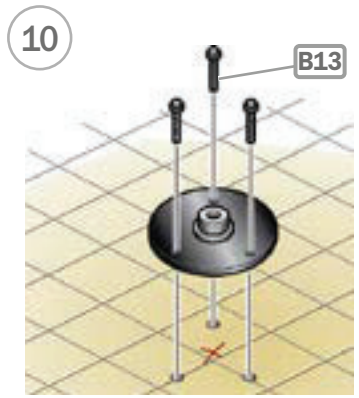
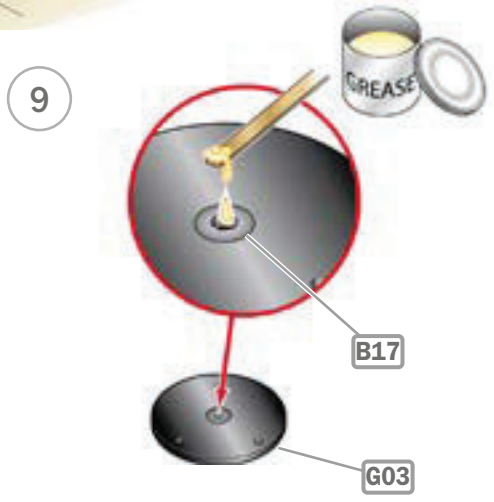
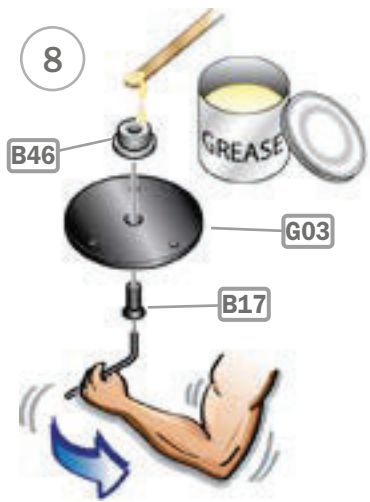
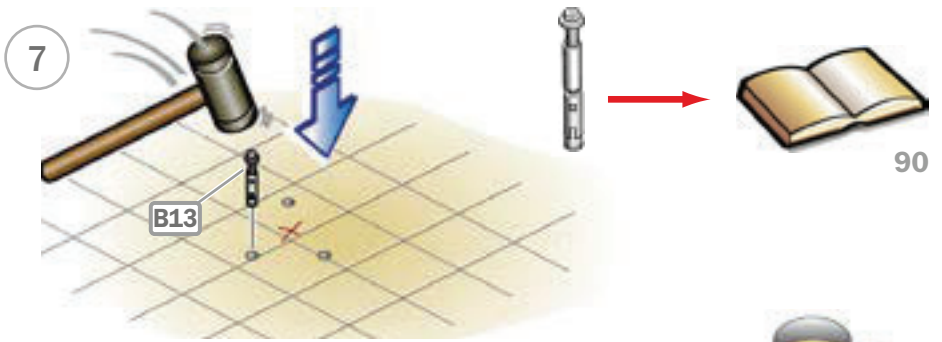

12

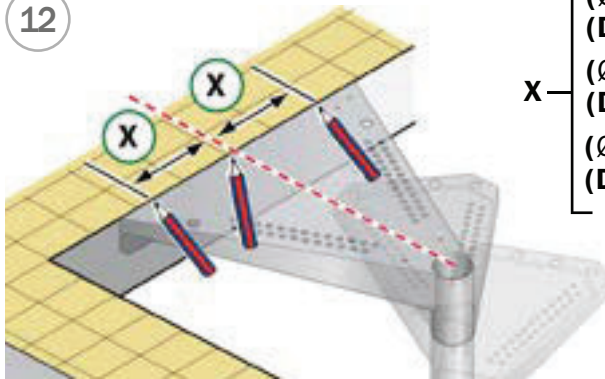

- (Ø 120 cm) = 29 cm
- (D 47 ¼") = 11 13/32"
- (Ø 140 cm) = 34,5 cm
- (D 55 ⅛") = 13 9/16"
- (Ø 160 cm) = 41 cm
- (D 63") = 16 1/8"

13

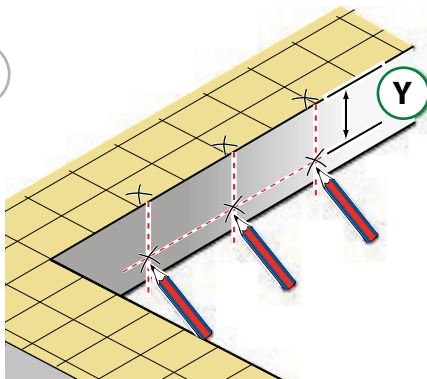

Y = 9,2 cm (3 5/8")

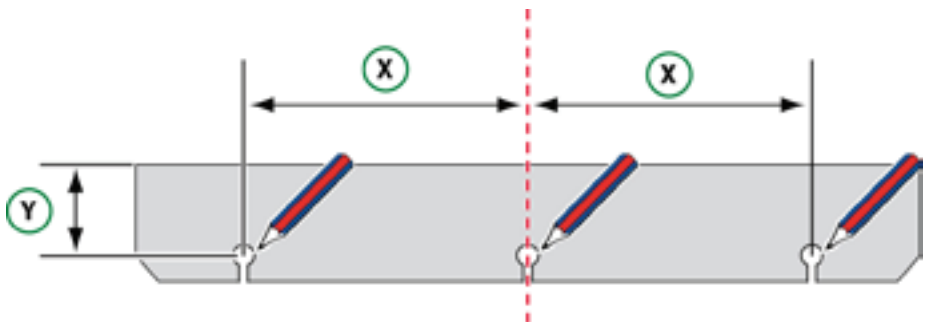

14

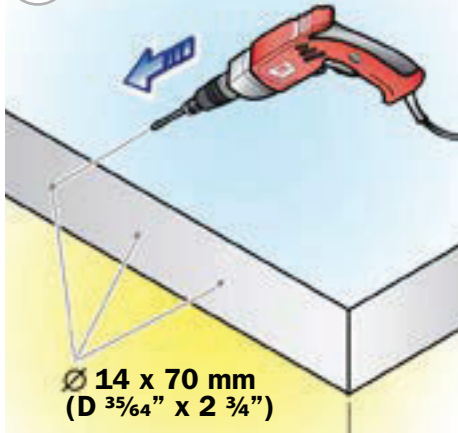

15

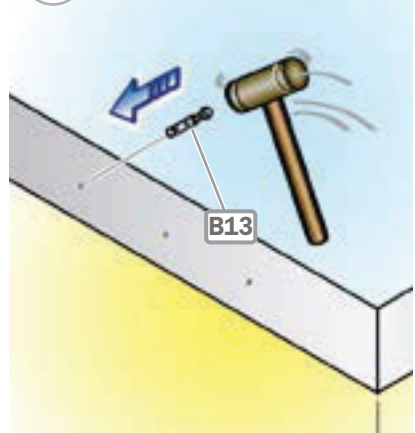

16

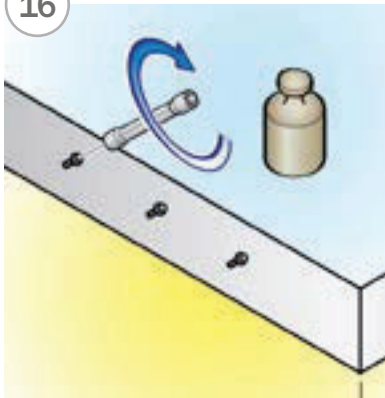

17

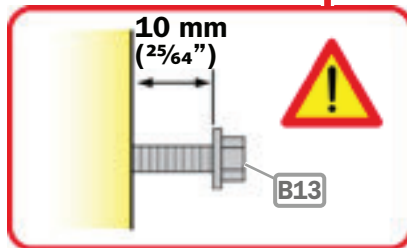
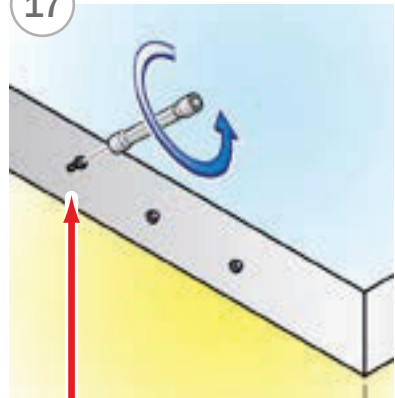

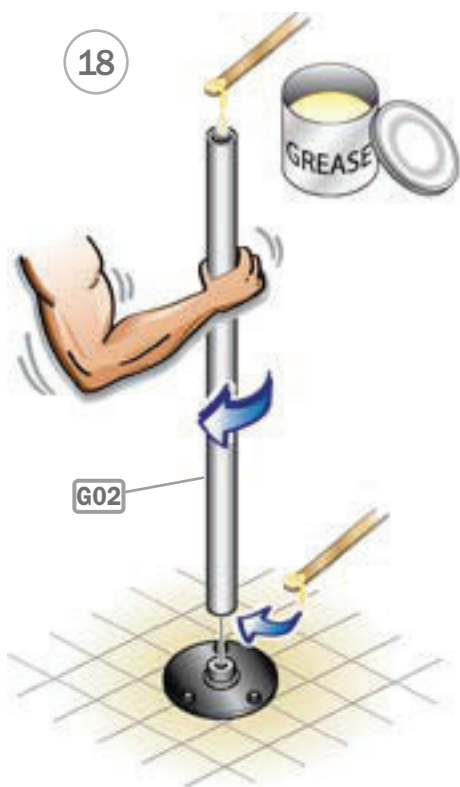

10



11



12



13



14



15



16





H cm	H inch	D02	D03	D04	D14
211	83 1/4"	10	0	9	1
212	83 3/8"	10	2	9	1
213	83 7/8"	10	4	9	1
214	84 1/8"	10	6	9	1
215	84 3/8"	10	8	9	1
216	85 1/8"	10	10	9	1
217	85 3/8"	10	12	9	1
218	85 7/8"	10	14	9	1
219	86 1/8"	10	16	9	1
220	86 3/8"	10	18	9	1
221	87"	10	20	9	1
222	87 3/8"	10	22	9	1
223	87 7/8"	10	24	9	1
224	88 1/8"	10	26	9	1
225	88 3/8"	10	28	9	1
226	89"	10	30	9	1
227	89 3/8"	10	32	9	1
228	89 7/8"	10	34	9	1
229	90 1/8"	10	36	9	1
230	90 3/8"	10	38	9	1
231	90 7/8"	10	40	9	1
232	91 1/8"	10	42	9	1
233	91 3/8"	10	44	9	1
234	92 1/8"	10	46	9	1
235	92 3/8"	10	48	9	1
236	92 7/8"	10	50	9	1

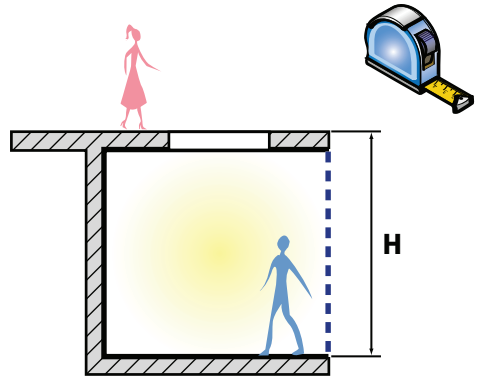

H = 227 cm (89 3/8")

- D02 = 10**
- D03 = 32**
- D04 = 9**
- D14 = 1**

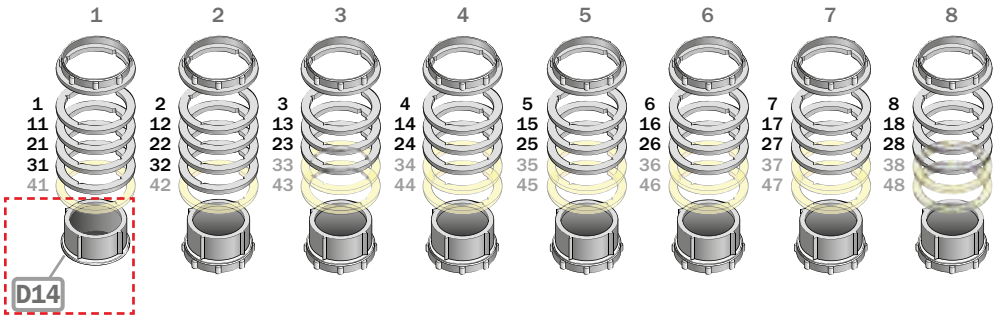

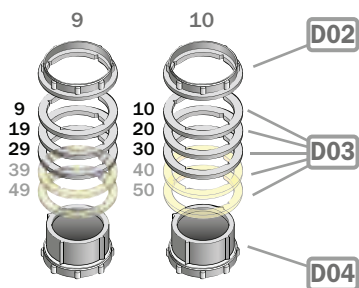
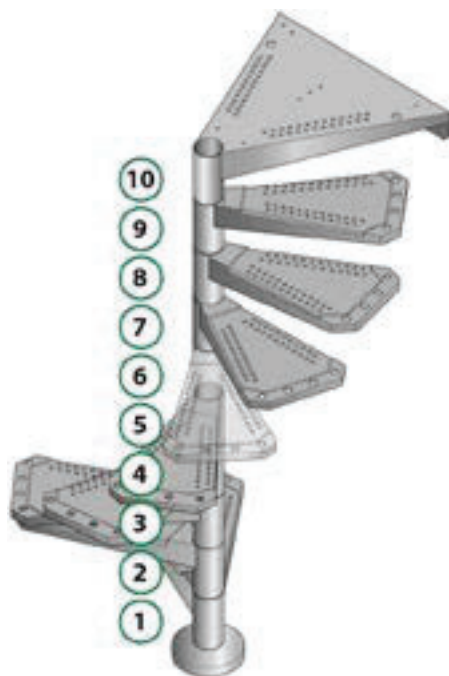

H cm	H inch	D02	D03	D04	D14
232	91 5/16"	11	1	10	1
233	91 3/4"	11	3	10	1
234	92 1/8"	11	5	10	1
235	92 1/2"	11	7	10	1
236	92 5/8"	11	9	10	1
237	93 3/16"	11	11	10	1
238	93 13/16"	11	13	10	1
239	94 1/8"	11	15	10	1
240	94 1/2"	11	17	10	1
241	94 7/8"	11	19	10	1
242	95 1/4"	11	21	10	1
243	95 13/16"	11	23	10	1
244	96 1/8"	11	25	10	1
245	96 7/16"	11	27	10	1
246	96 3/8"	11	29	10	1
247	97 1/4"	11	31	10	1
248	97 5/8"	11	33	10	1
249	98 1/16"	11	35	10	1
250	98 7/16"	11	37	10	1
251	98 13/16"	11	39	10	1
252	99 3/16"	11	41	10	1
253	99 5/8"	11	43	10	1
254	100"	11	45	10	1
255	100 3/8"	11	47	10	1
256	100 13/16"	11	49	10	1
257	101 3/16"	11	51	10	1
258	101 5/8"	11	53	10	1
259	101 15/16"	11	55	10	1

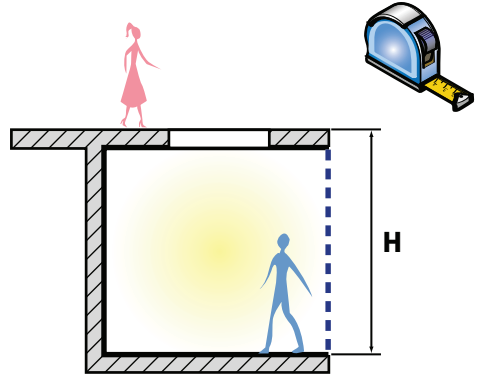

H = 251 cm
(98 13/16")



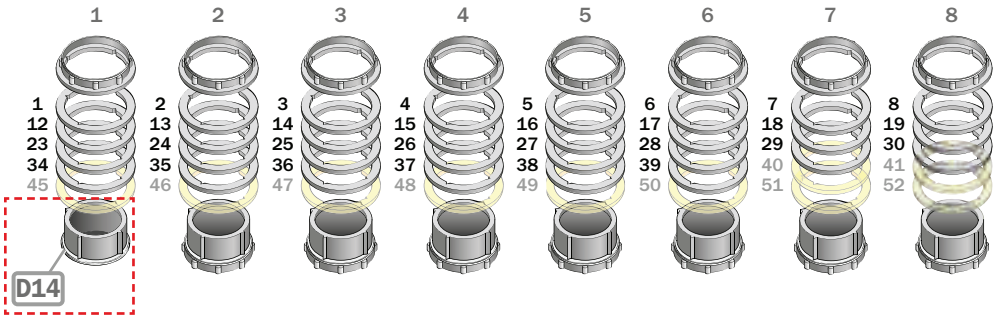

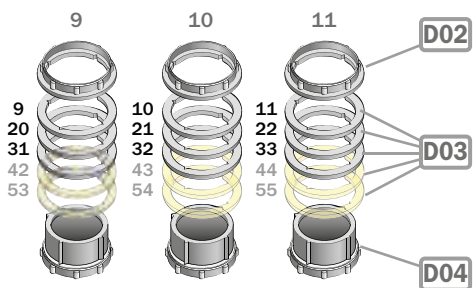
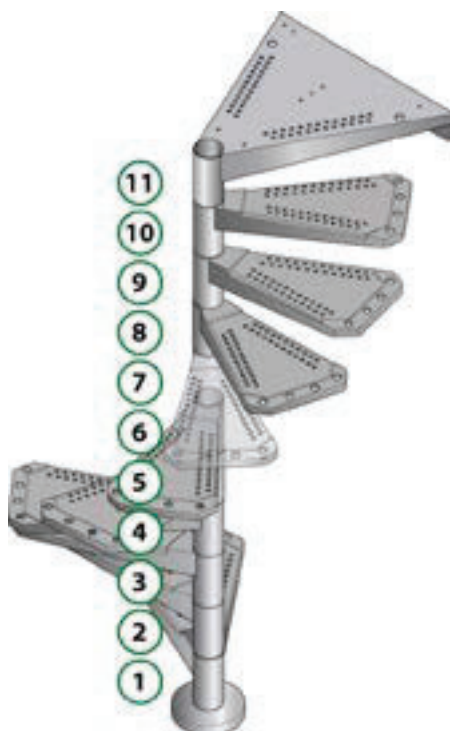
- D02 = 11**
- D03 = 39**
- D04 = 10**
- D14 = 1**



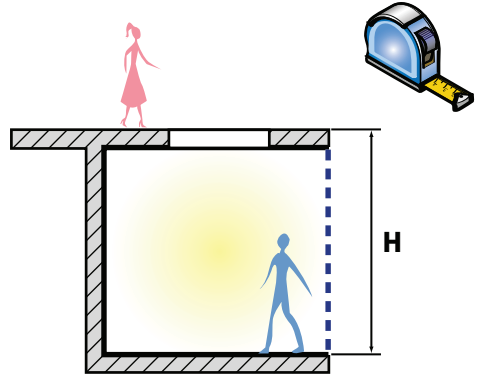

H cm	H inch	D02	D03	D04	D14
253	99 7/8"	12	0	11	1
254	100 "	12	2	11	1
255	100 3/8"	12	4	11	1
256	100 13/16"	12	6	11	1
257	101 1/16"	12	8	11	1
258	101 1/2"	12	10	11	1
259	101 3/4"	12	12	11	1
260	102 1/8"	12	14	11	1
261	102 1/4"	12	16	11	1
262	103 1/8"	12	18	11	1
263	103 1/2"	12	20	11	1
264	103 3/4"	12	22	11	1
265	104 1/16"	12	24	11	1
266	104 3/4"	12	26	11	1
267	105 1/8"	12	28	11	1
268	105 1/2"	12	30	11	1
269	105 3/4"	12	32	11	1
270	106 1/16"	12	34	11	1
271	106 3/8"	12	36	11	1
272	107 1/16"	12	38	11	1
273	107 1/2"	12	40	11	1
274	107 7/8"	12	42	11	1
275	108 1/4"	12	44	11	1
276	108 3/8"	12	46	11	1
277	109 1/16"	12	48	11	1
278	109 3/8"	12	50	11	1
279	109 13/16"	12	52	11	1
280	110 1/4"	12	54	11	1
281	110 3/8"	12	56	11	1
282	111 "	12	58	11	1
283	111 7/16"	12	60	11	1



D02 = 12 
D03 = 42 
H = 274 cm (107 7/8")
D04 = 11 
D14 = 1 

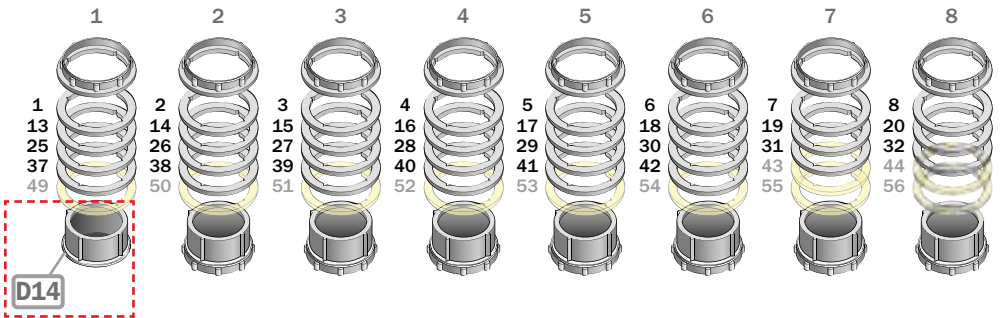

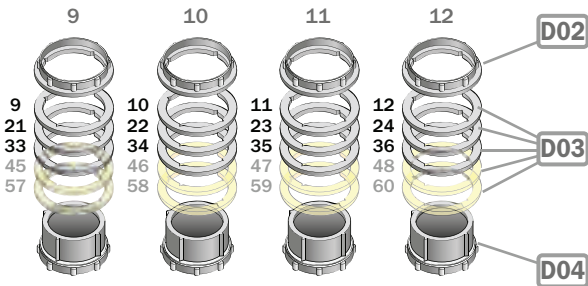
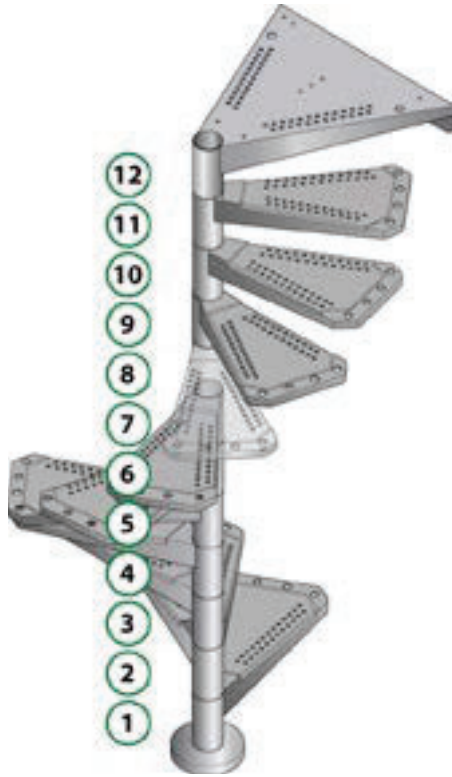



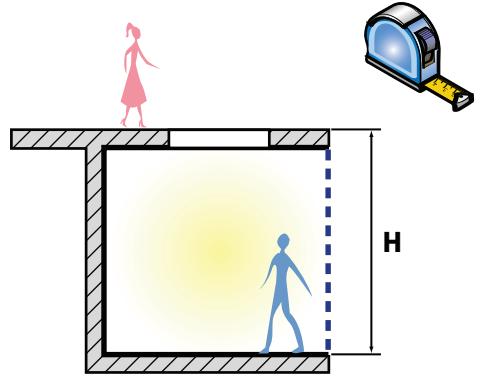

H cm	H inch	D02	D03	D04	D14
274	107 7/8"	13	1	12	1
275	108 1/4"	13	3	12	1
276	108 1/2"	13	5	12	1
277	109 1/8"	13	7	12	1
278	109 3/16"	13	9	12	1
279	109 1/2"	13	11	12	1
280	110 1/4"	13	13	12	1
281	110 5/8"	13	15	12	1
282	111 "	13	17	12	1
283	111 7/16"	13	19	12	1
284	111 3/4"	13	21	12	1
285	112 3/8"	13	23	12	1
286	112 5/8"	13	25	12	1
287	113 "	13	27	12	1
288	113 3/8"	13	29	12	1
289	113 3/4"	13	31	12	1
290	114 3/16"	13	33	12	1
291	114 1/2"	13	35	12	1
292	114 5/8"	13	37	12	1
293	115 3/8"	13	39	12	1
294	115 3/4"	13	41	12	1
295	116 1/8"	13	43	12	1
296	116 1/2"	13	45	12	1
297	116 5/8"	13	47	12	1
298	117 5/16"	13	49	12	1
299	117 1/2"	13	51	12	1
300	118 1/8"	13	53	12	1
301	118 1/2"	13	55	12	1
302	118 7/8"	13	57	12	1
303	119 3/16"	13	59	12	1
304	119 1/2"	13	61	12	1
305	120 1/8"	13	63	12	1
306	120 1/2"	13	65	12	1



**H = 298 cm
(117 5/16")**

- D02 = 13** 
- D03 = 49** 
- D04 = 12** 
- D14 = 1** 

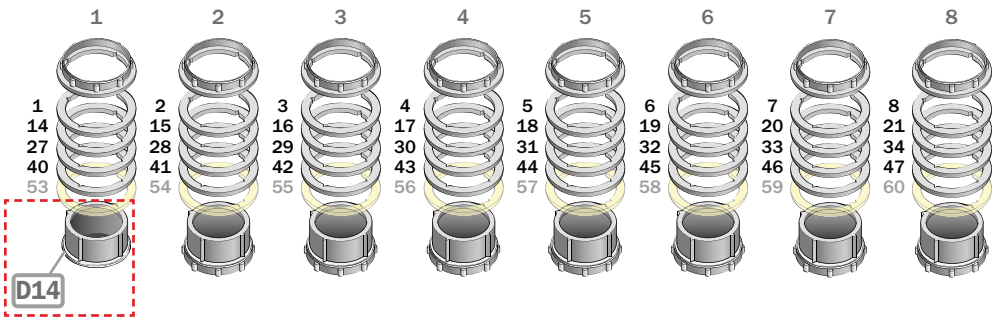

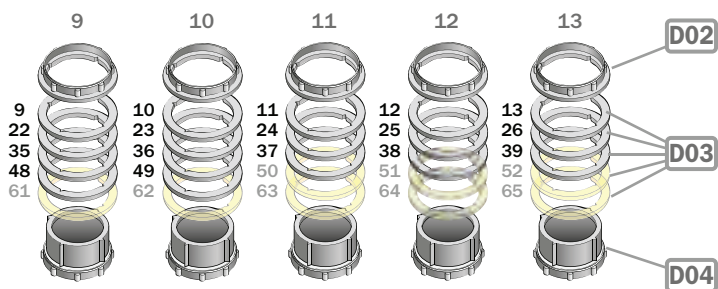
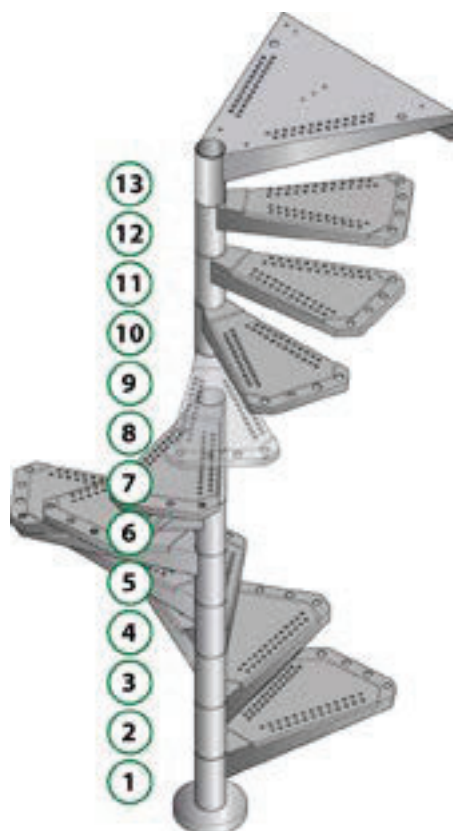

H cm	H inch	D02	D03	D04	D14
295	116 1/8"	14	0	13	1
296	116 3/16"	14	2	13	1
297	116 1/2"	14	4	13	1
298	117 1/4"	14	6	13	1
299	117 1/2"	14	8	13	1
300	118 1/8"	14	10	13	1
301	118 1/2"	14	12	13	1
302	118 3/4"	14	14	13	1
303	119 1/4"	14	16	13	1
304	119 1/2"	14	18	13	1
305	120 1/4"	14	20	13	1
306	120 1/2"	14	22	13	1
307	120 3/4"	14	24	13	1
308	121 1/4"	14	26	13	1
309	121 1/2"	14	28	13	1
310	122 1/4"	14	30	13	1
311	122 3/8"	14	32	13	1
312	122 1/2"	14	34	13	1
313	123 1/4"	14	36	13	1
314	123 3/8"	14	38	13	1
315	124 "	14	40	13	1
316	124 1/4"	14	42	13	1
317	124 3/8"	14	44	13	1
318	125 1/4"	14	46	13	1
319	125 3/8"	14	48	13	1
320	126 "	14	50	13	1
321	126 1/4"	14	52	13	1
322	126 3/8"	14	54	13	1
323	127 1/4"	14	56	13	1
324	127 3/8"	14	58	13	1
325	127 1/2"	14	60	13	1
326	128 1/4"	14	62	13	1
327	128 3/8"	14	64	13	1
328	129 1/4"	14	66	13	1
329	129 1/2"	14	68	13	1
330	129 3/4"	14	70	13	1

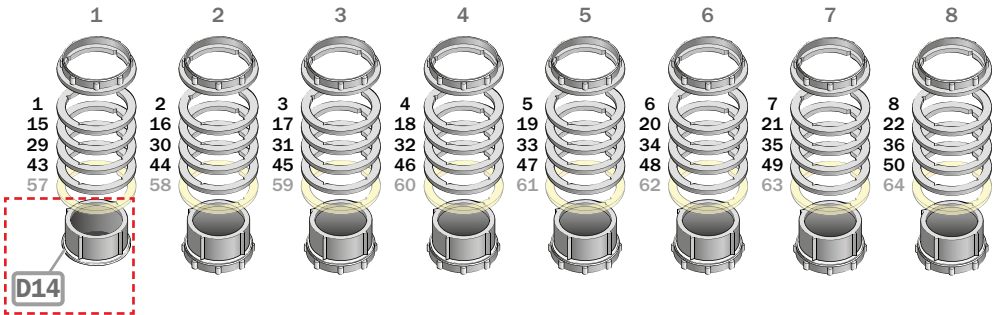
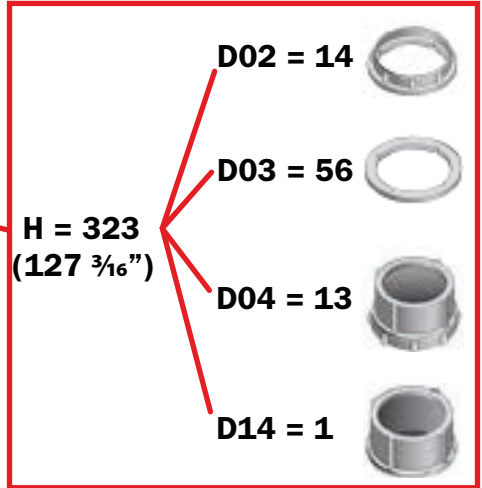
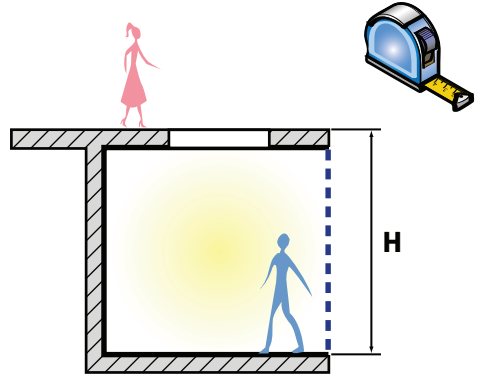

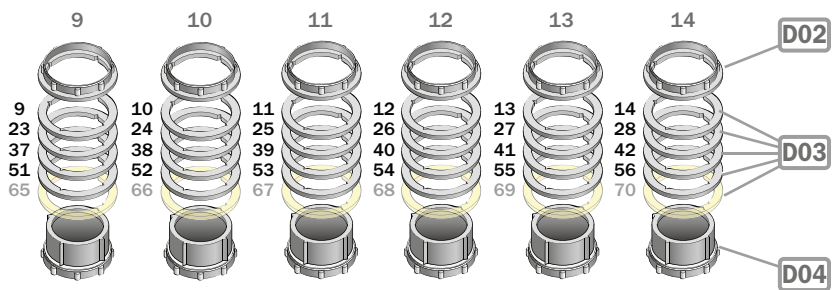
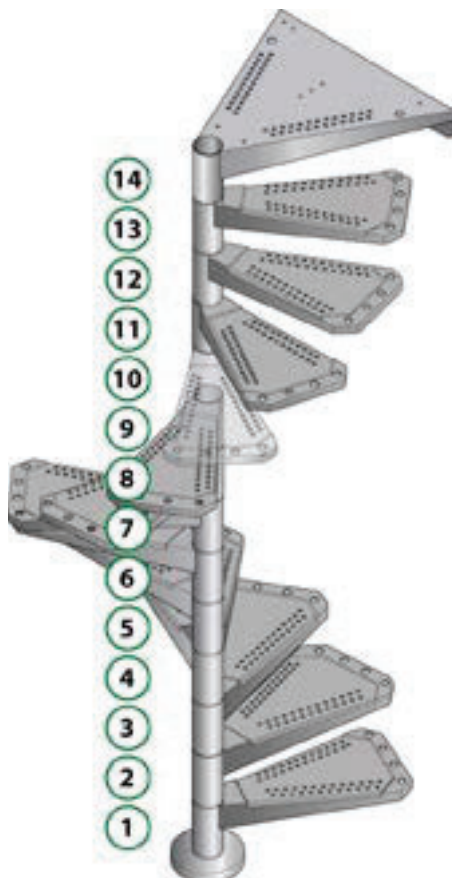

H cm	H inch	D02	D03	D04	D14
316	124 7/16"	15	1	14	1
317	124 13/16"	15	3	14	1
318	125 3/16"	15	5	14	1
319	125 9/16"	15	7	14	1
320	126 "	15	9	14	1
321	126 3/8"	15	11	14	1
322	126 3/4"	15	13	14	1
323	127 3/16"	15	15	14	1
324	127 9/16"	15	17	14	1
325	127 13/16"	15	19	14	1
326	128 3/8"	15	21	14	1
327	128 3/4"	15	23	14	1
328	129 1/8"	15	25	14	1
329	129 1/2"	15	27	14	1
330	129 13/16"	15	29	14	1
331	130 5/16"	15	31	14	1
332	130 11/16"	15	33	14	1
333	131 1/8"	15	35	14	1
334	131 1/2"	15	37	14	1
335	131 7/8"	15	39	14	1
336	132 3/16"	15	41	14	1
337	132 13/16"	15	43	14	1
338	133 1/16"	15	45	14	1
339	133 7/16"	15	47	14	1
340	133 3/8"	15	49	14	1
341	134 1/4"	15	51	14	1
342	134 5/8"	15	53	14	1
343	135 19/16"	15	55	14	1
344	135 7/16"	15	57	14	1
345	135 13/16"	15	59	14	1
346	136 1/4"	15	61	14	1
347	136 5/8"	15	63	14	1
348	137 "	15	65	14	1
349	137 3/8"	15	67	14	1
350	137 13/16"	15	69	14	1
351	138 3/16"	15	71	14	1
352	138 9/16"	15	73	14	1
353	139 "	15	75	14	1

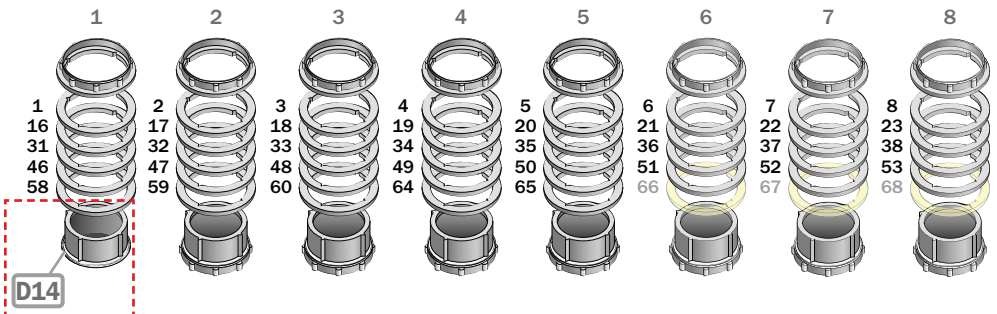
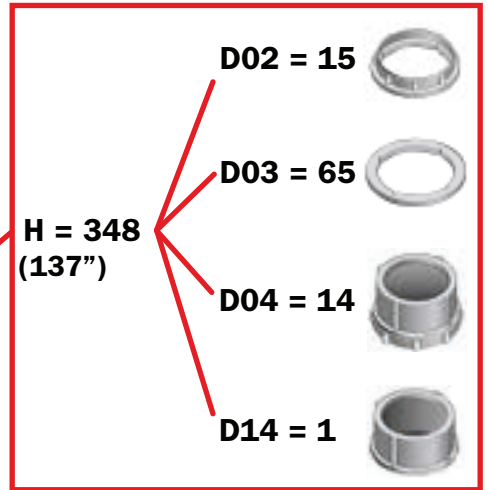
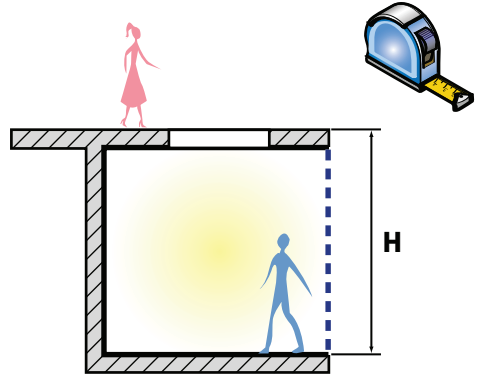

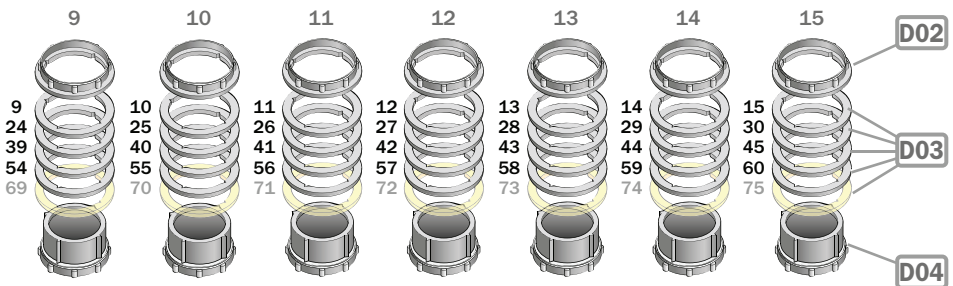
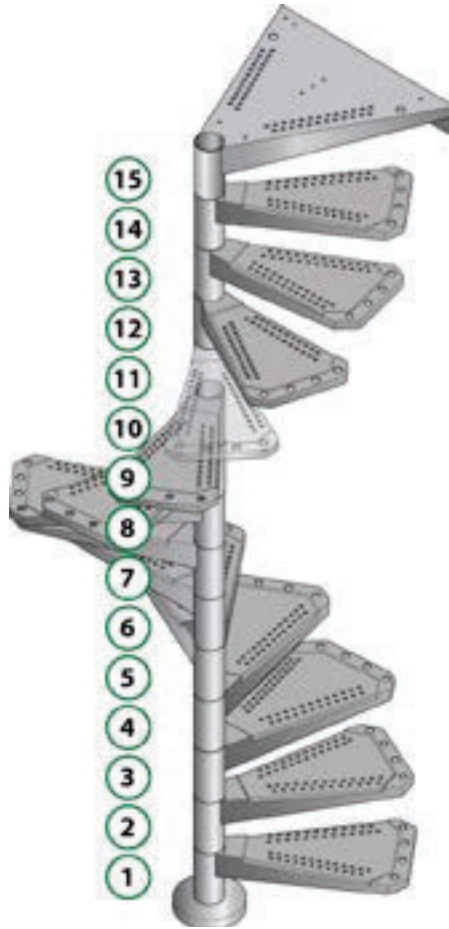



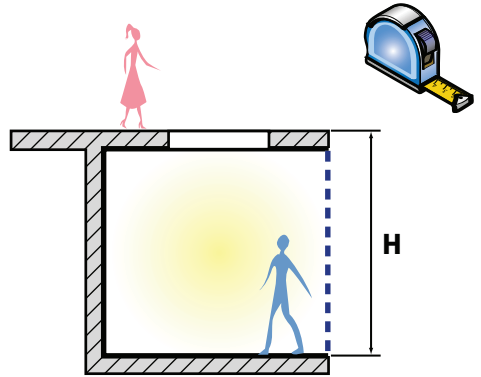

H cm	H inch	D02	D03	D04	D14
337	132 1/16"	16	0	15	1
338	133 1/16"	16	2	15	1
339	133 3/16"	16	4	15	1
340	133 7/16"	16	6	15	1
341	134 1/4"	16	8	15	1
342	134 5/8"	16	10	15	1
343	135 1/16"	16	12	15	1
344	135 3/16"	16	14	15	1
345	135 7/16"	16	16	15	1
346	136 1/4"	16	18	15	1
347	136 5/8"	16	20	15	1
348	137"	16	22	15	1
349	137 3/8"	16	24	15	1
350	137 7/8"	16	26	15	1
351	138 1/16"	16	28	15	1
352	138 3/16"	16	30	15	1
353	139"	16	32	15	1
354	139 3/8"	16	34	15	1
355	139 3/4"	16	36	15	1
356	140 1/16"	16	38	15	1
357	140 3/16"	16	40	15	1
358	140 7/16"	16	42	15	1
359	141 1/16"	16	44	15	1
360	141 3/4"	16	46	15	1
361	142 1/8"	16	48	15	1
362	142 1/2"	16	50	15	1
363	142 5/16"	16	52	15	1
364	143 3/16"	16	54	15	1
365	143 7/16"	16	56	15	1
366	144 1/8"	16	58	15	1
367	144 1/2"	16	60	15	1
368	144 7/8"	16	62	15	1
369	145 1/4"	16	64	15	1
370	145 5/16"	16	66	15	1
371	146 1/16"	16	68	15	1
372	146 3/16"	16	70	15	1
373	146 7/8"	16	72	15	1
374	147 1/4"	16	74	15	1
375	147 3/8"	16	76	15	1
376	148 1/16"	16	78	15	1
377	148 3/16"	16	80	15	1



**H = 369
(145 1/4")**

- D02 = 16** 
- D03 = 64** 
- D04 = 15** 
- D14 = 1** 

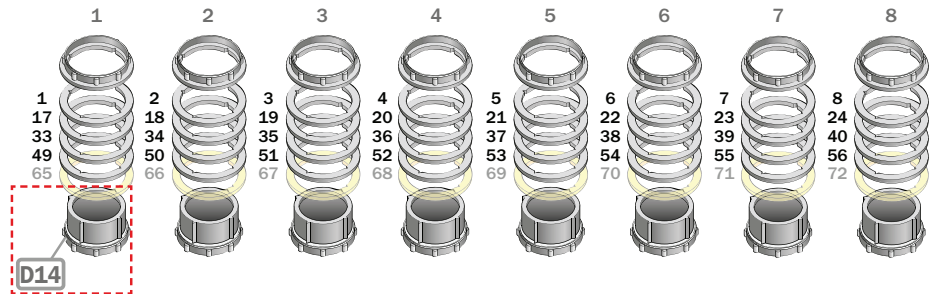

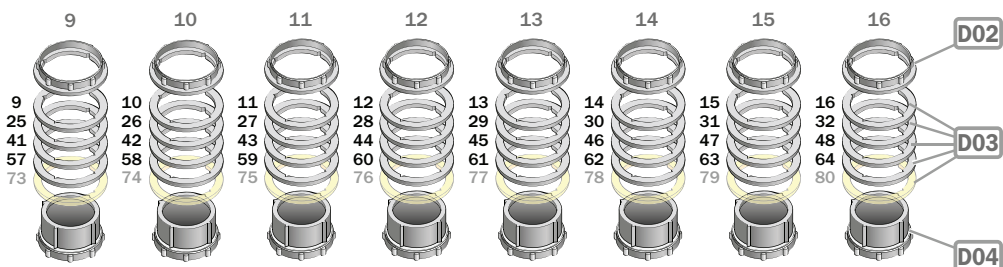
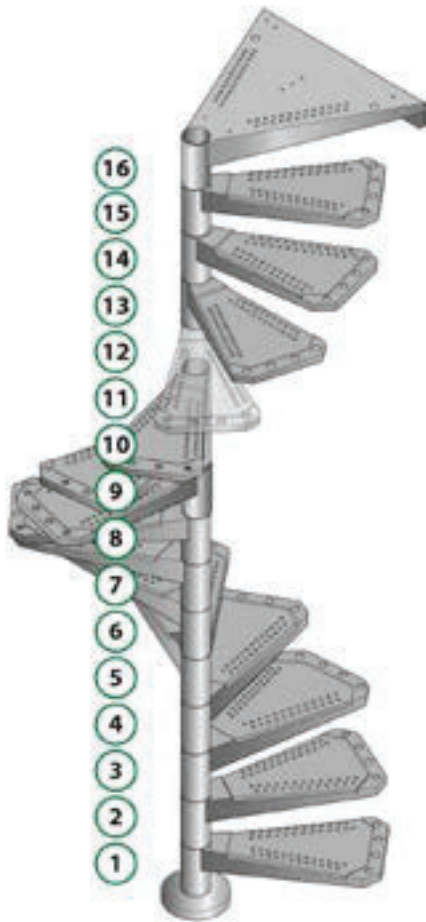

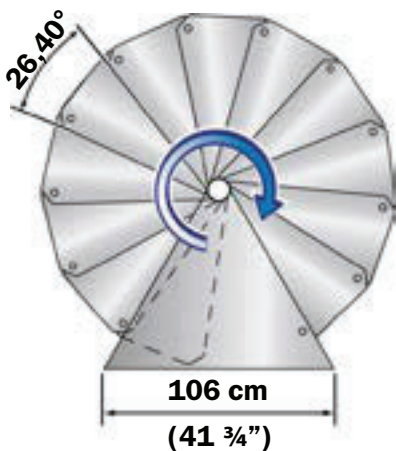

Ø 160 cm
(D 63")

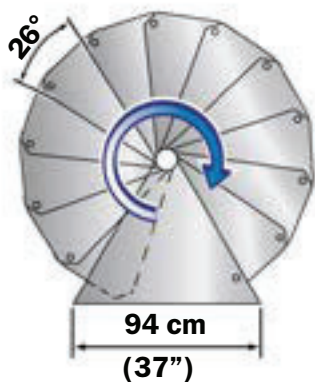
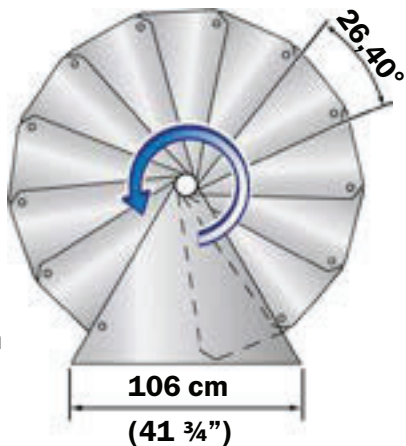

Ø 140 cm
(D 55 1/8")

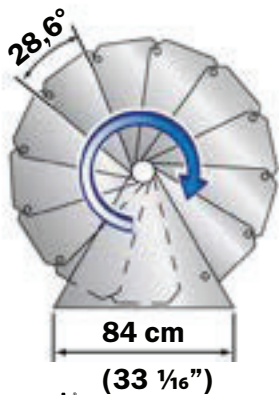
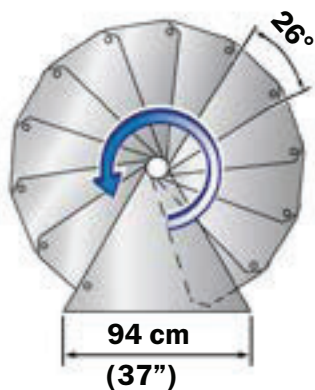

Ø 120 cm
(D 47 1/4")

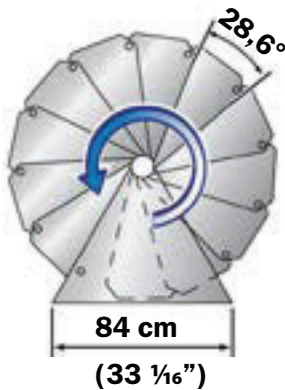

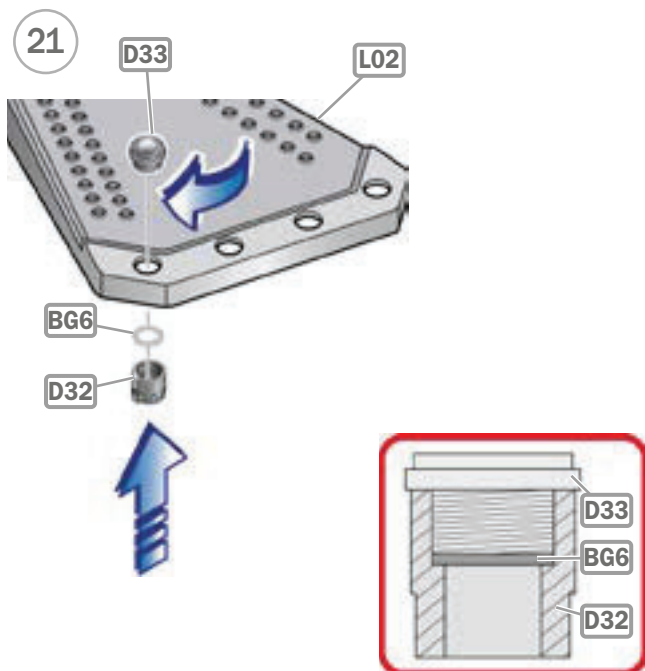
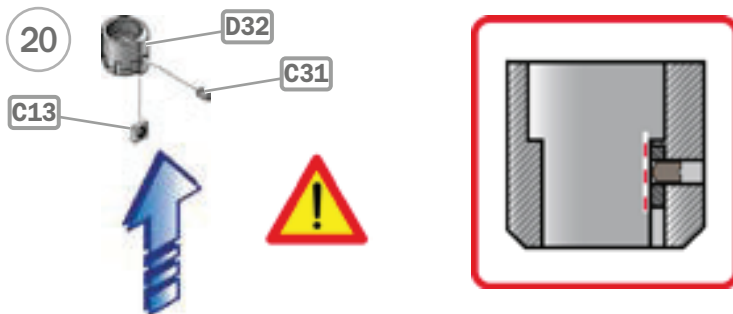



22

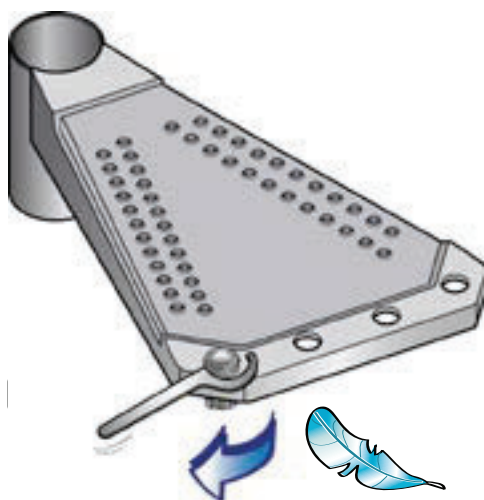

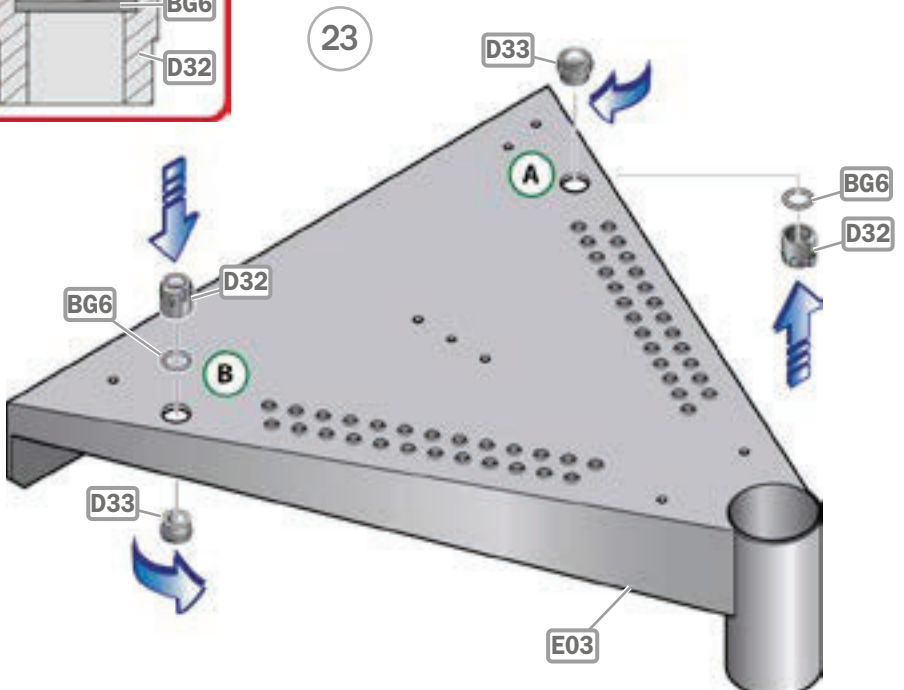
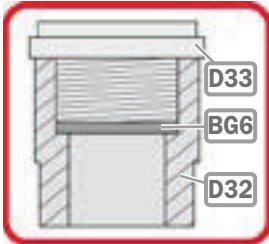
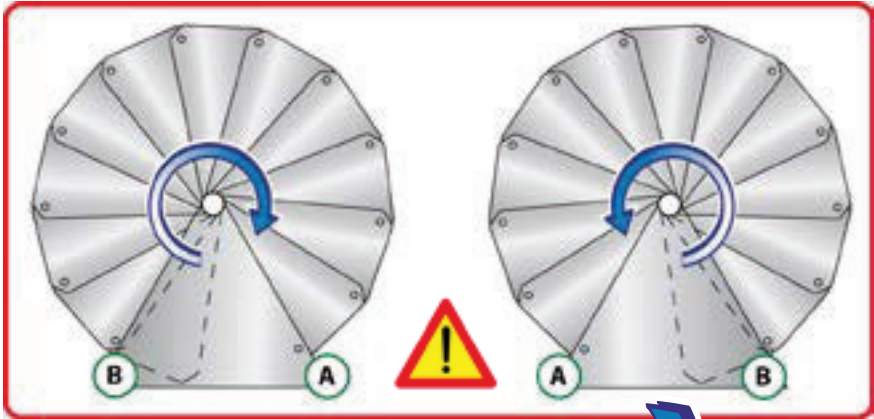

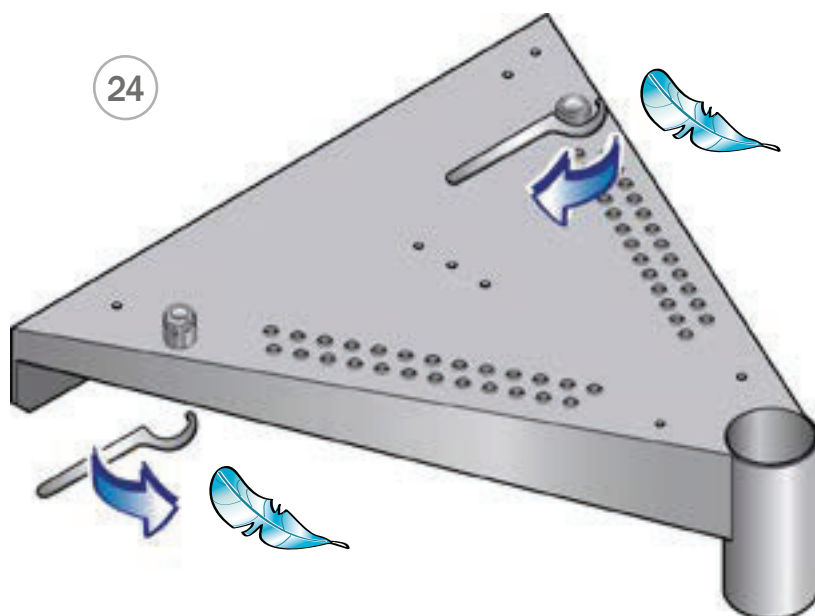
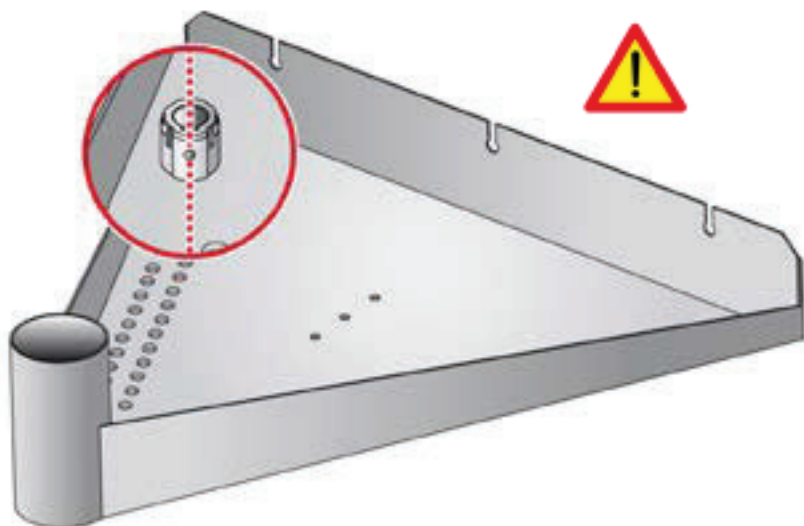

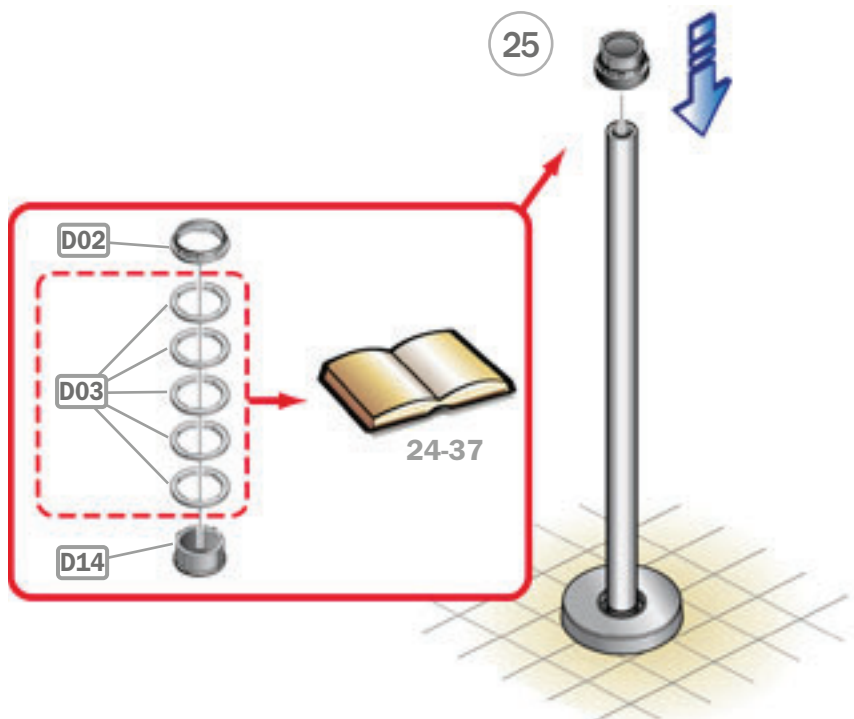

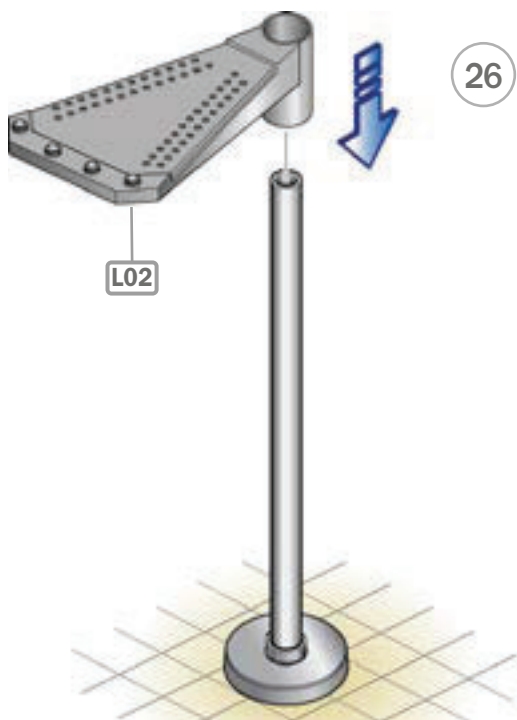

26

L02

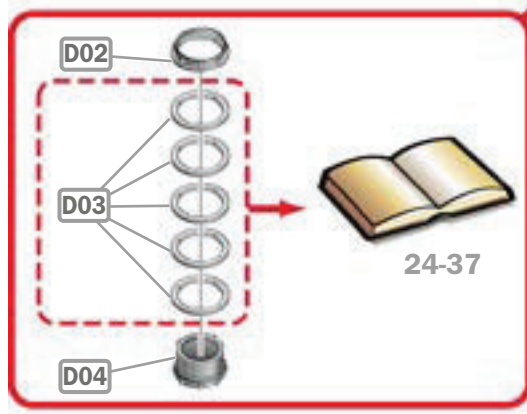

27

24-37

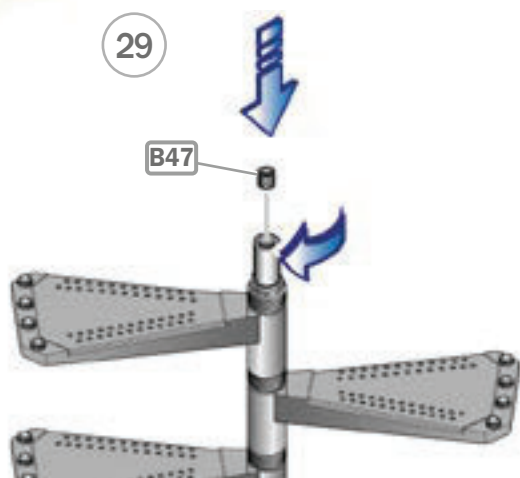
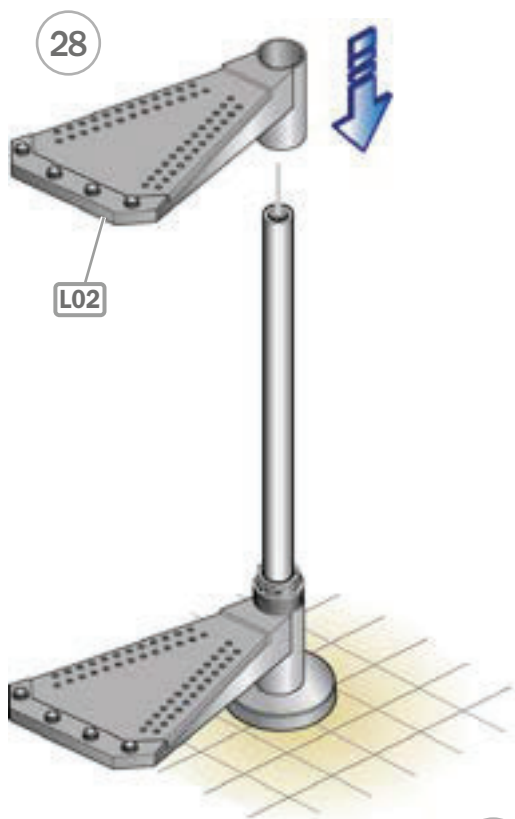

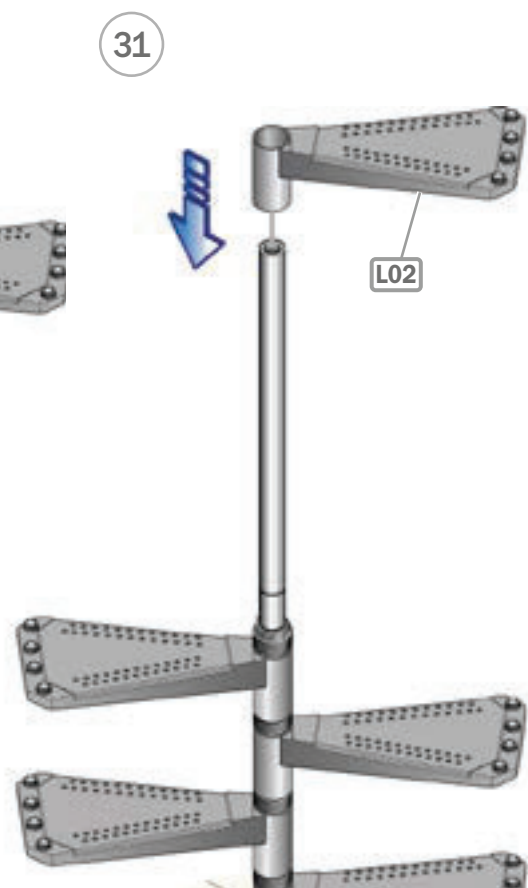
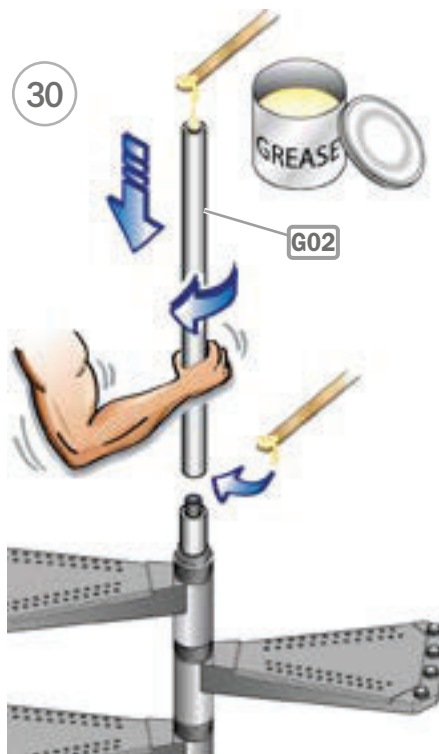

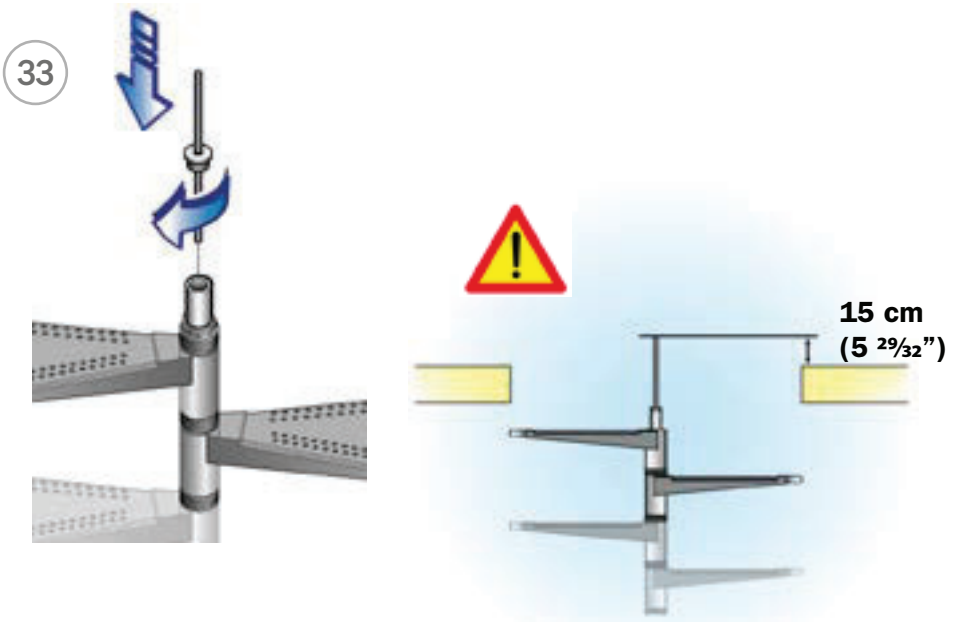
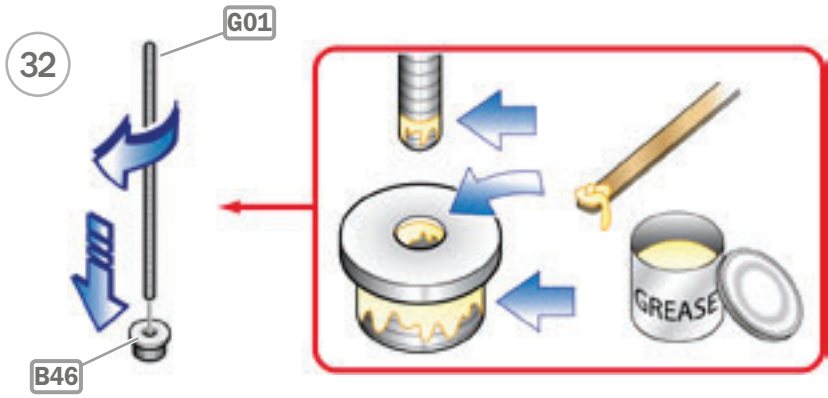

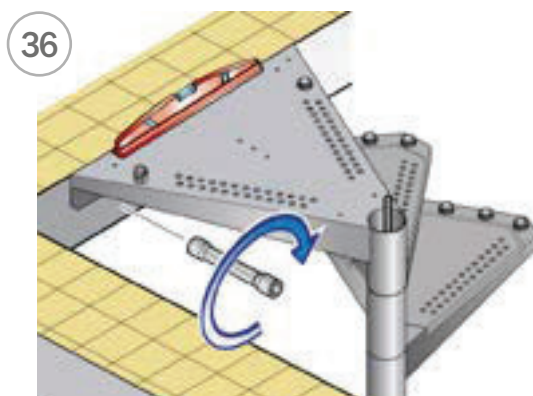
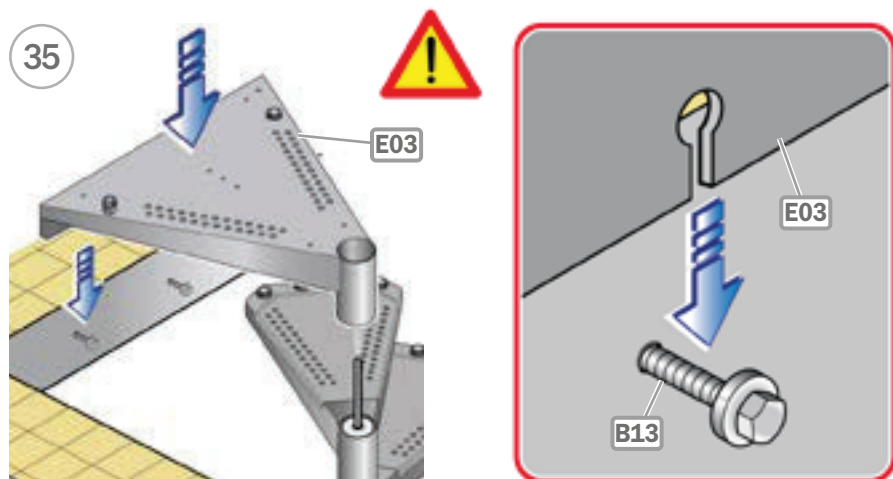
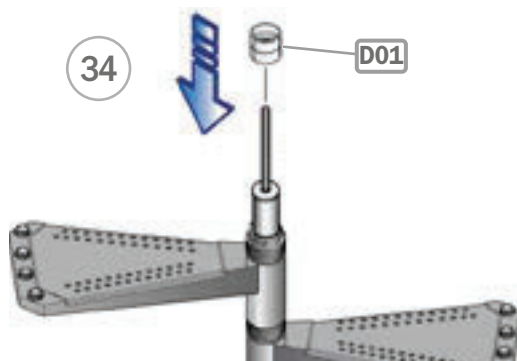

37

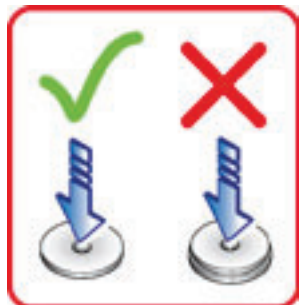
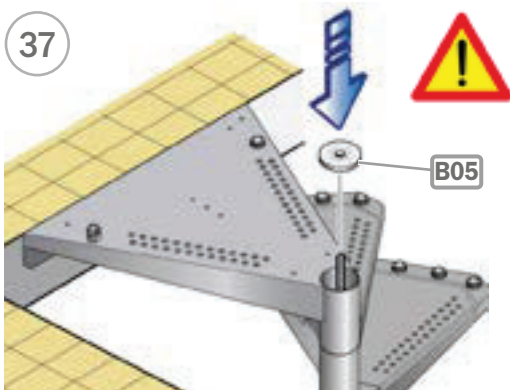

38

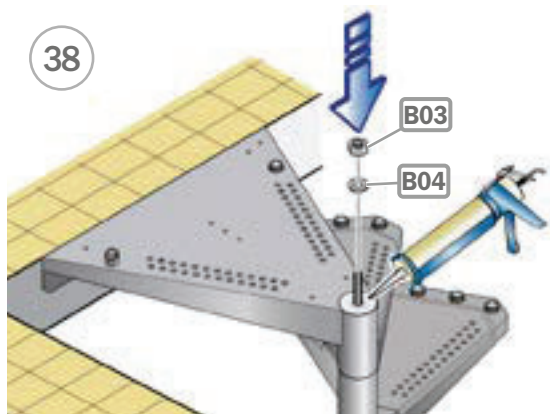

39

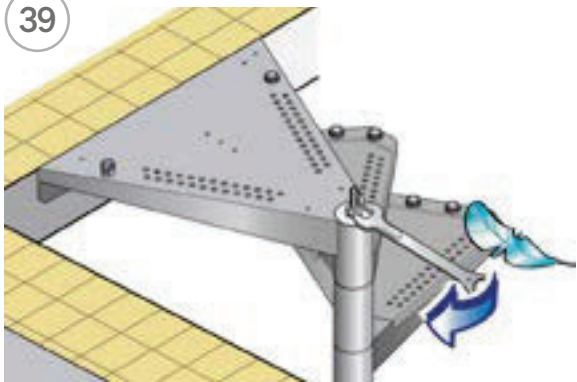

40



41

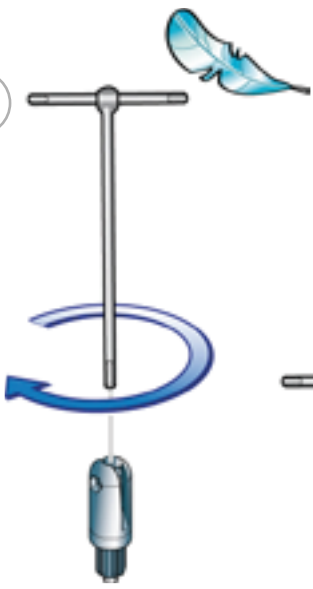

43

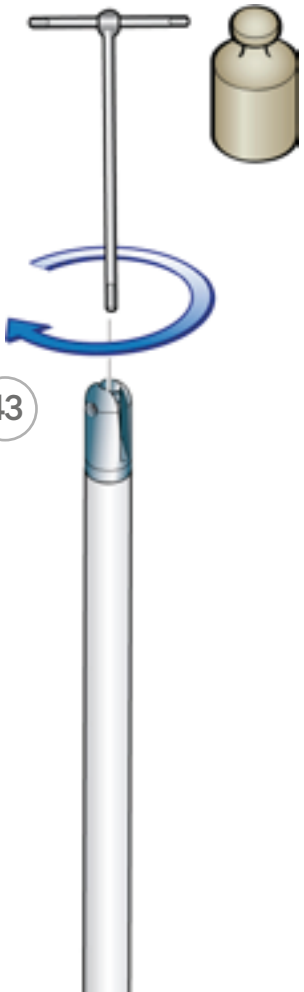

42

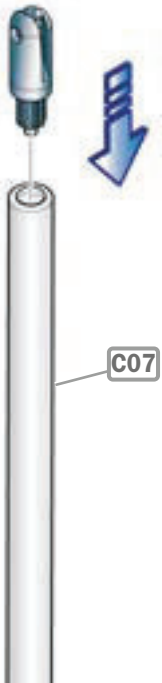

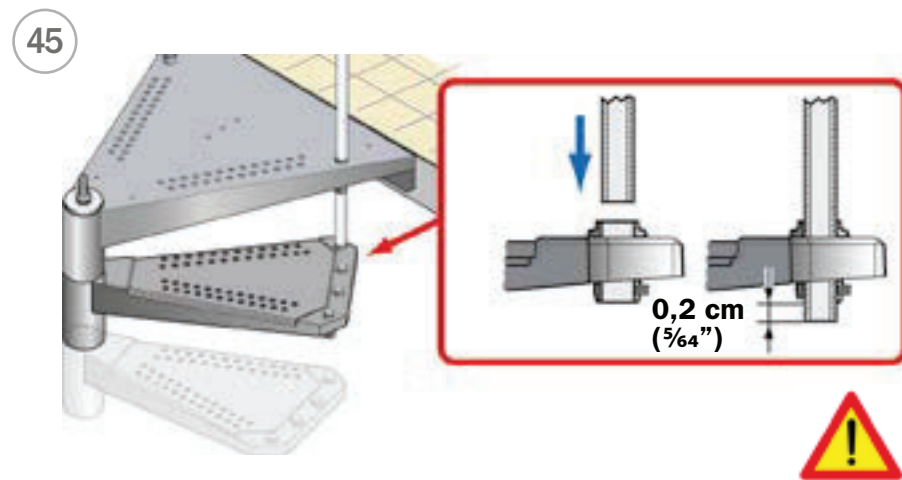
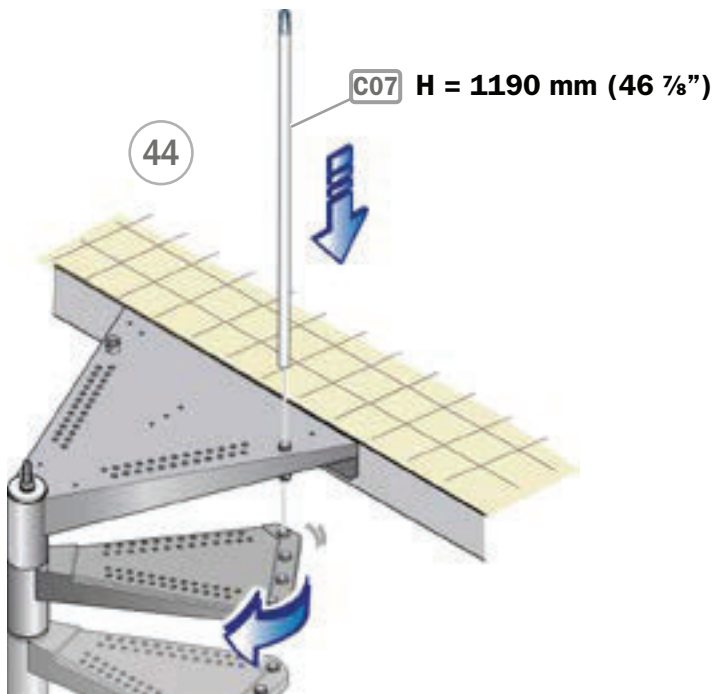

46

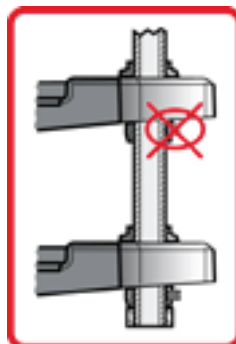
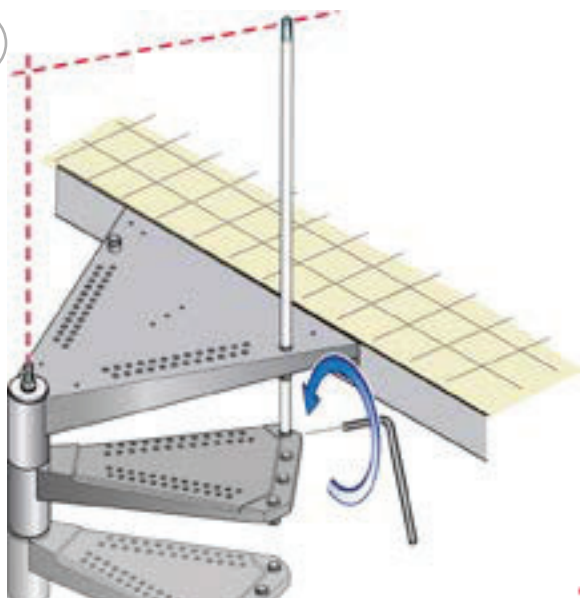

47

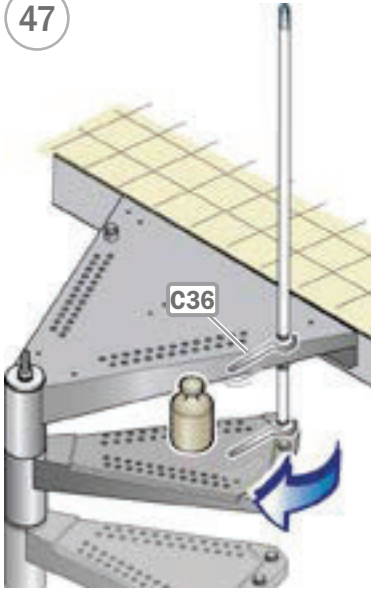

48

H = 1190 mm
(46 7/8")

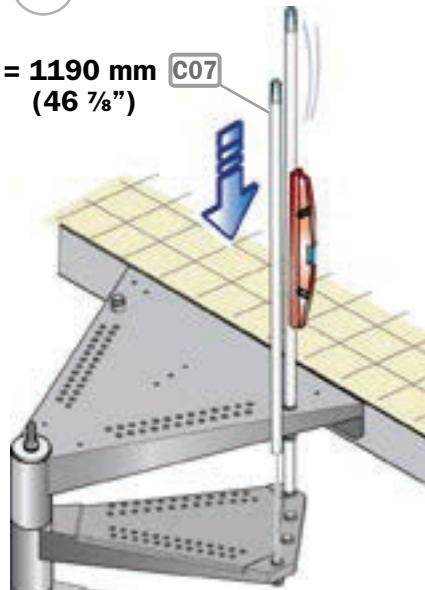

49

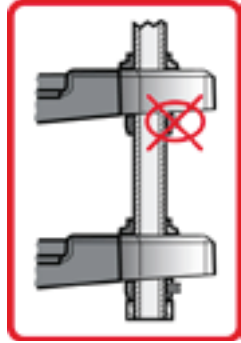
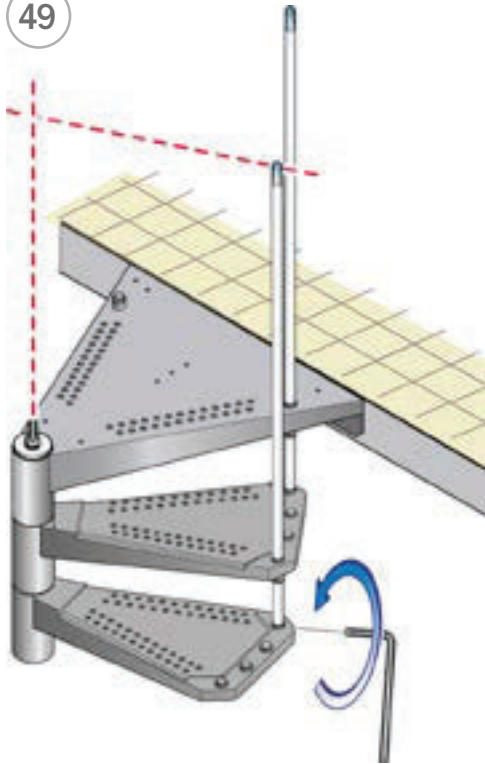

50

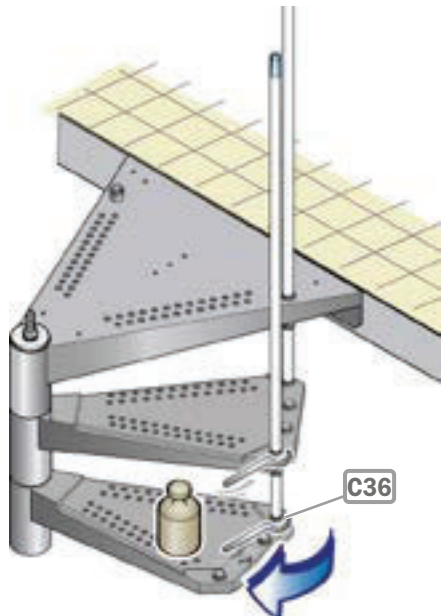

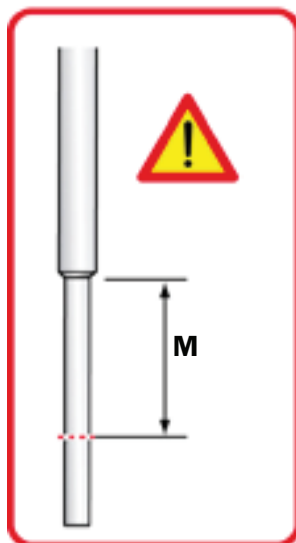
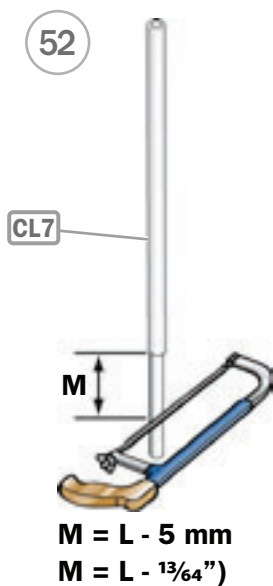
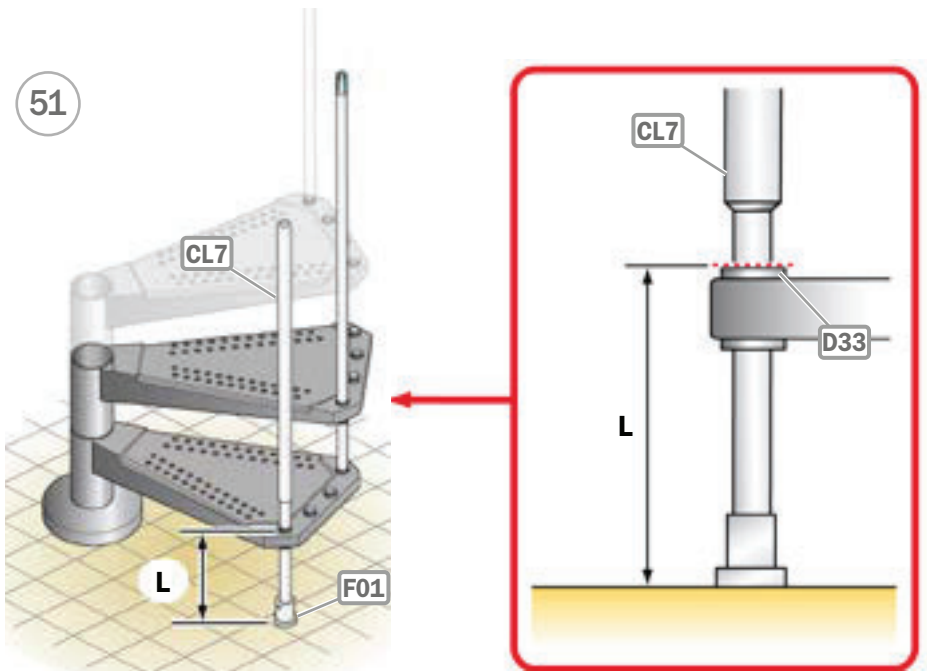

54

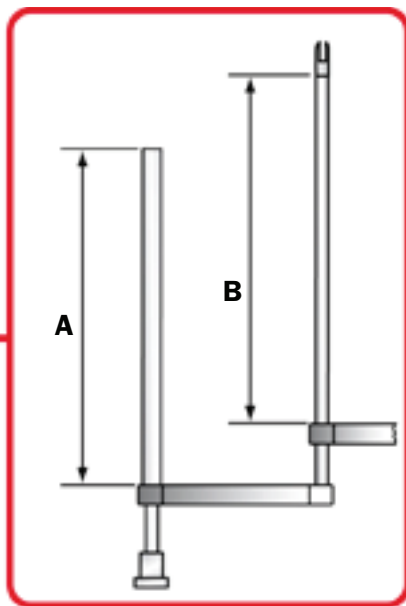
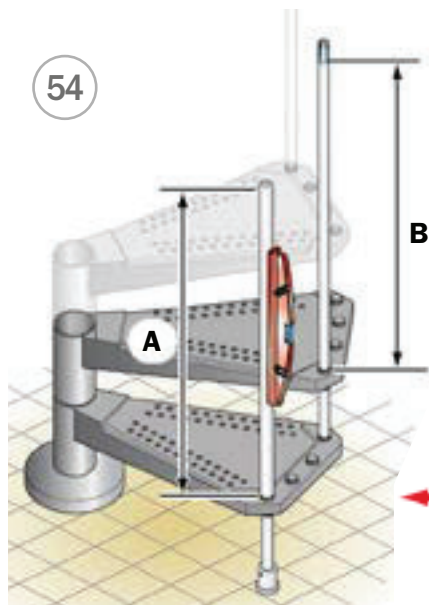

55

$$C = A - (B + 8 \text{ mm})$$

$$C = A - (B + \frac{5}{16} \text{''})$$

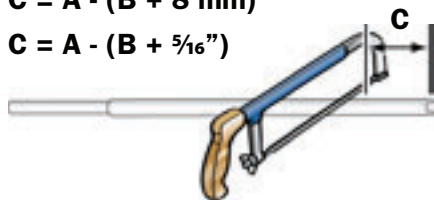

56



57



58

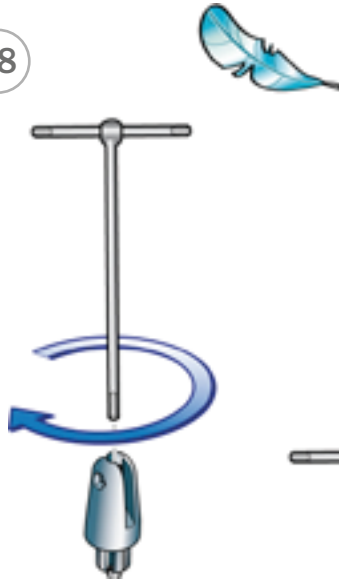

59

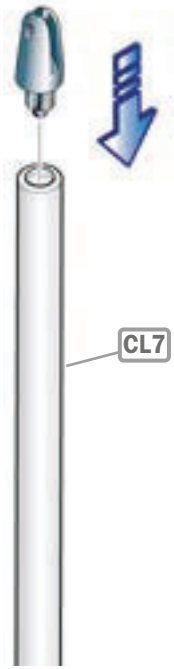

60



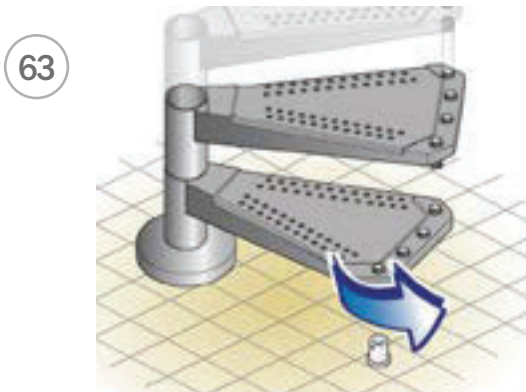
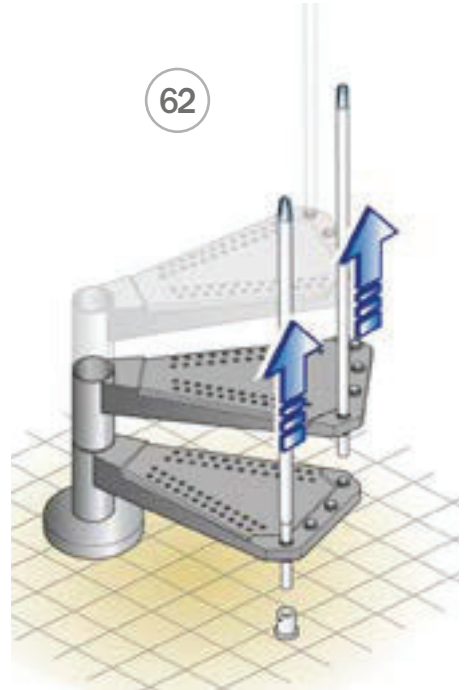
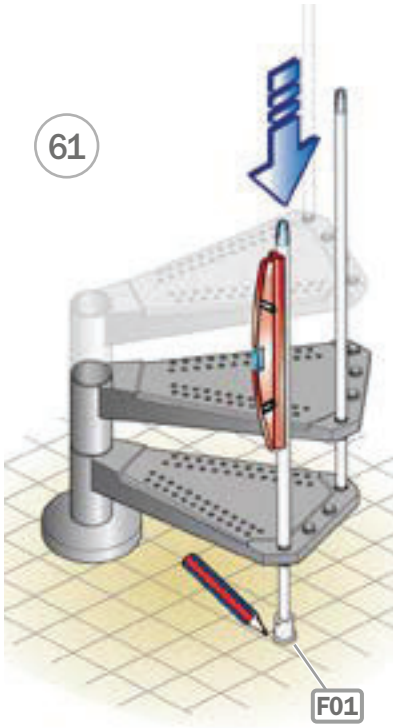

64

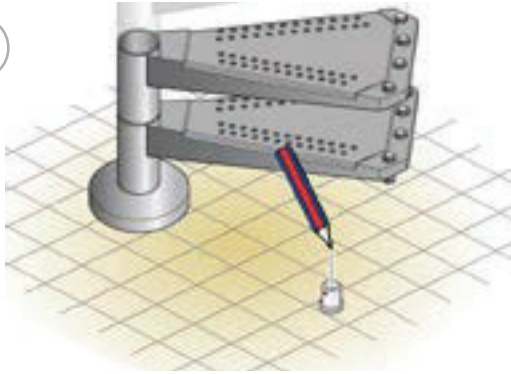

65

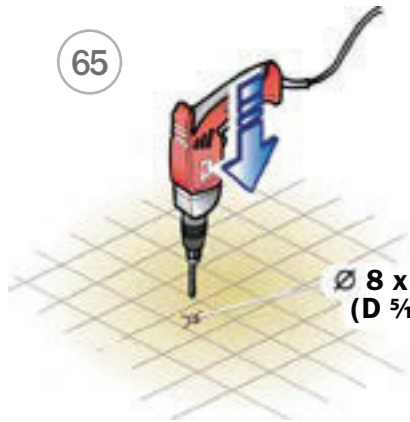

Ø 8 x 50 mm
(D 5/16" x 1 31/32")

66

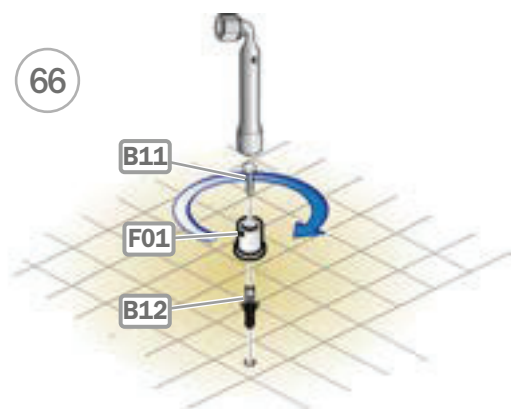

67

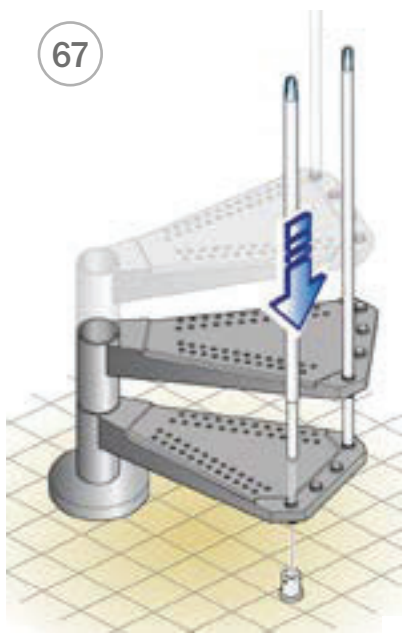

68

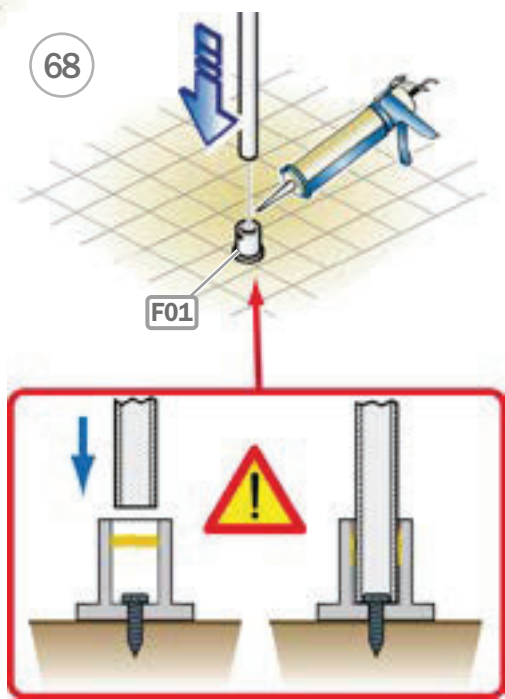

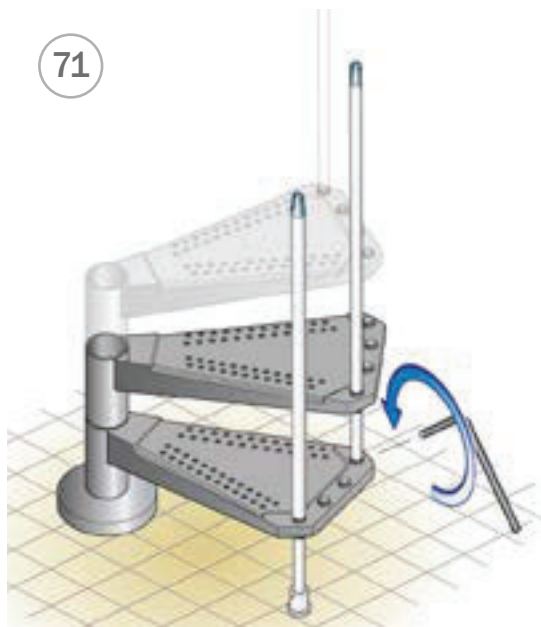
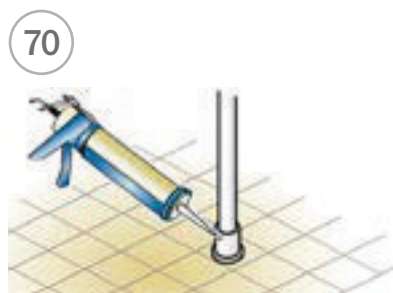
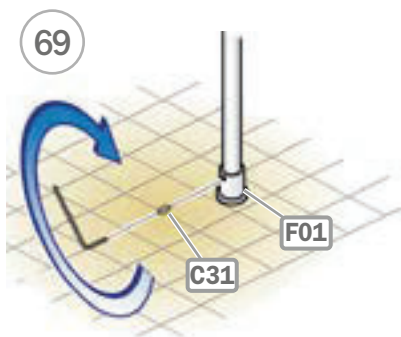

72

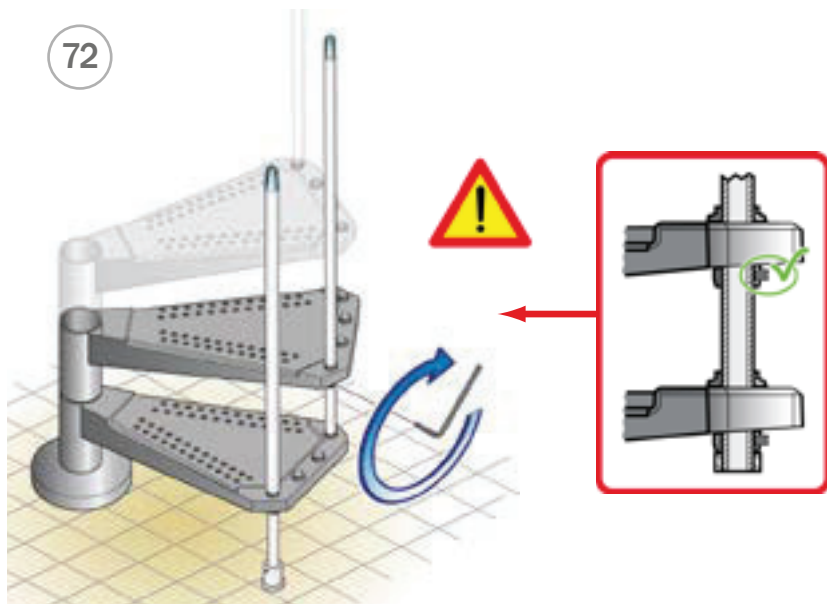

73

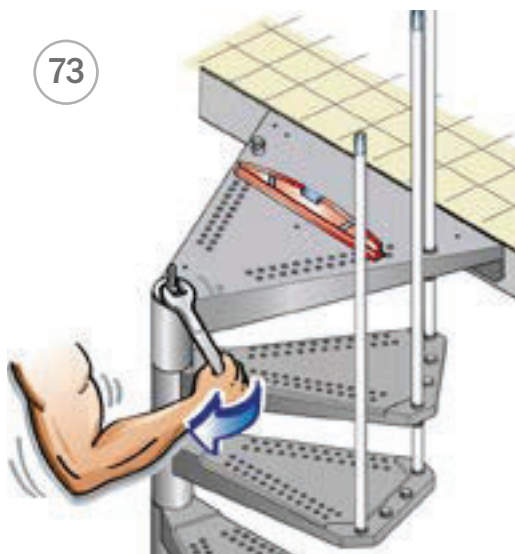

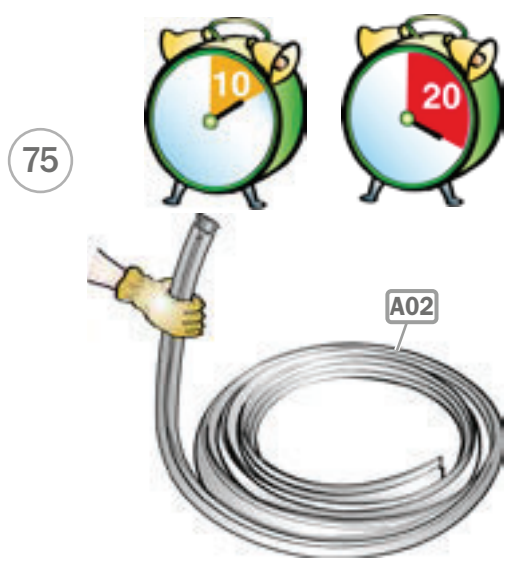
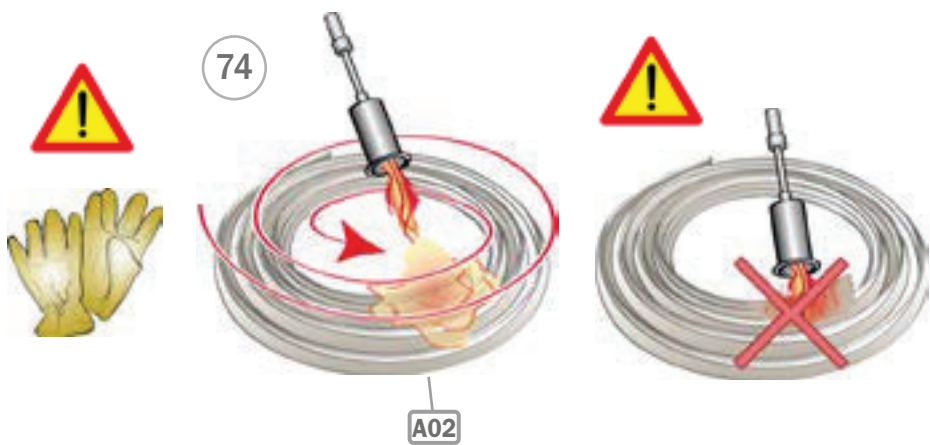

76

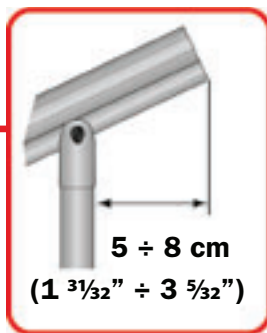
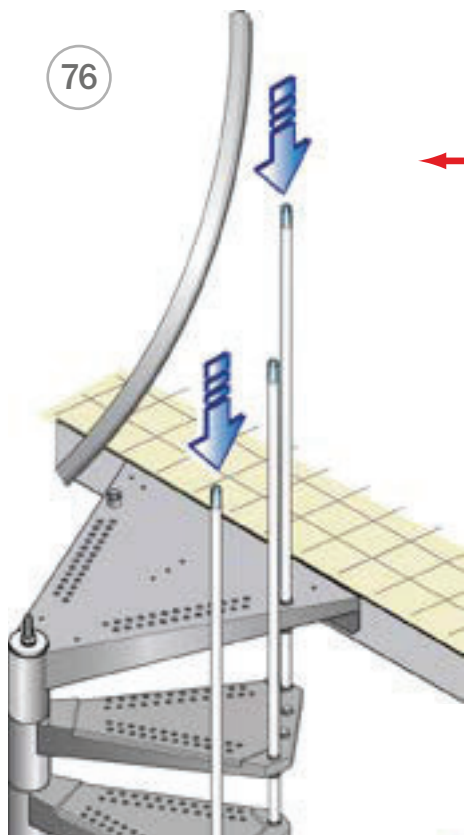

77

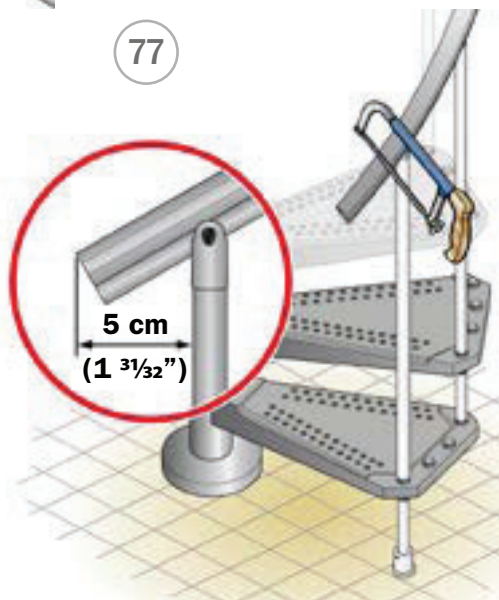

78

Ø 5,5 mm (D 7/32")

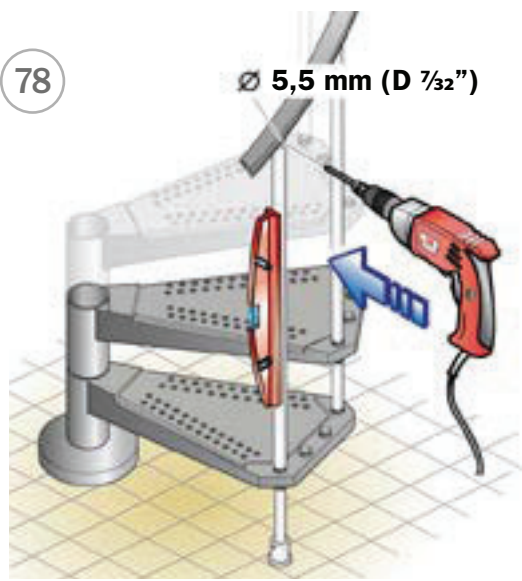

79

B54

B55

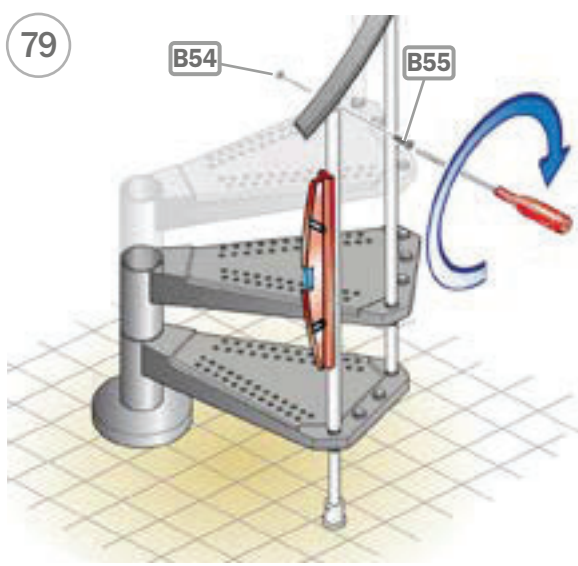

Ø 120 cm (D 47 ¼")

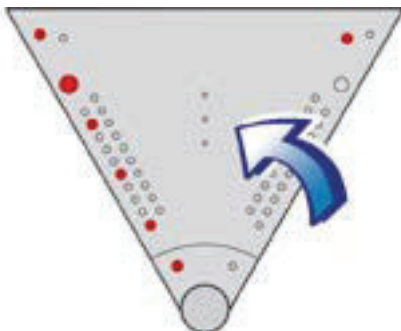

Ø 140 cm (D 55 ⅛")

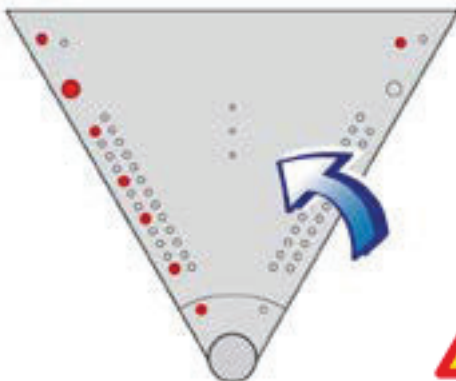

Ø 160 cm (D 63")

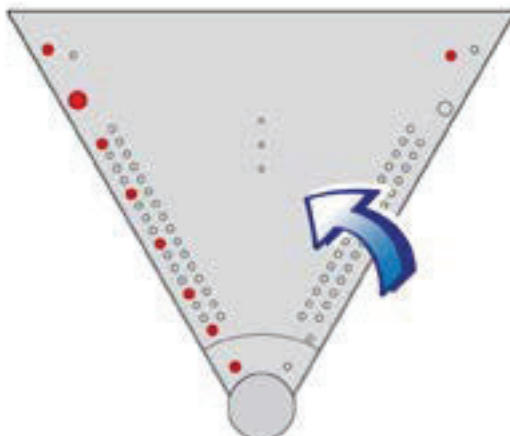

Ø 120 cm (D 47 ¼")

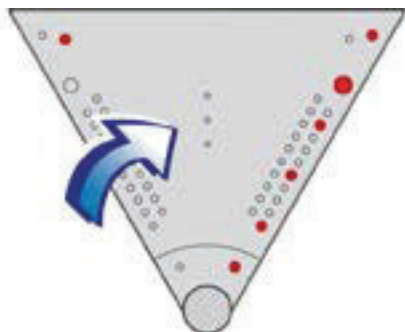

Ø 140 cm (D 55 ½")

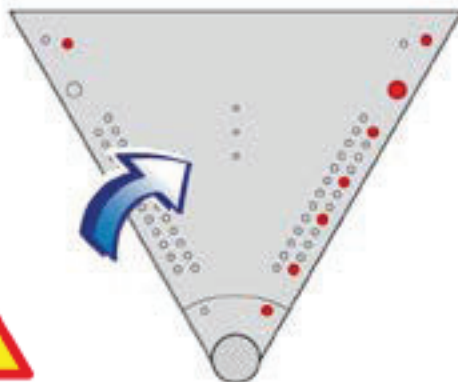

Ø 160 cm (D 63")

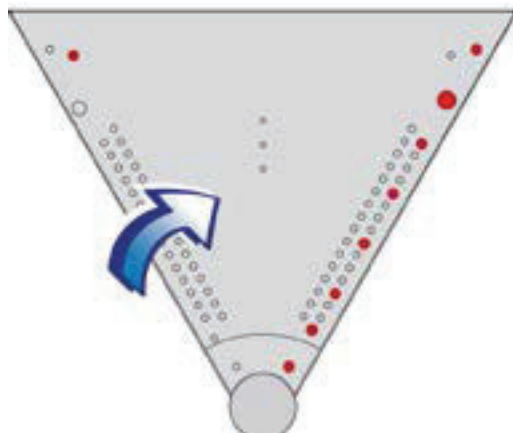

80

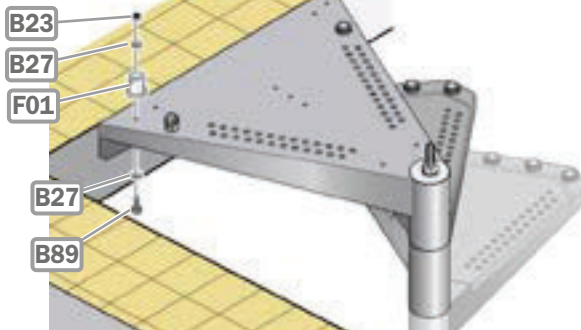

66-67

81

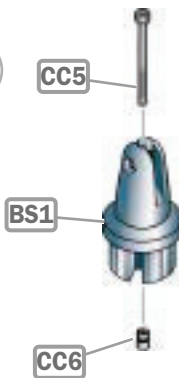

82

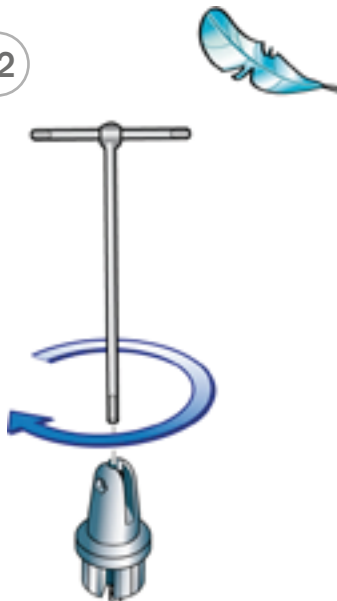

83



84



85

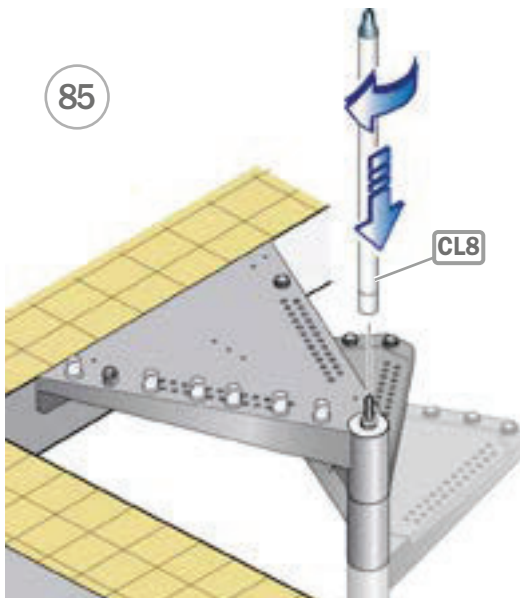

86

H = 935 mm (36 13/16")

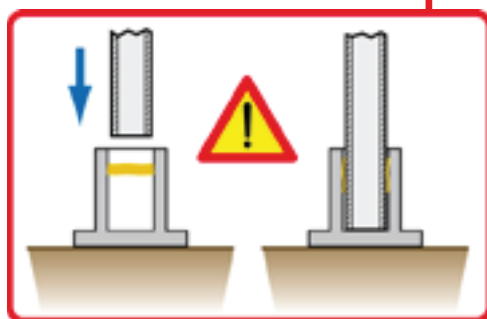
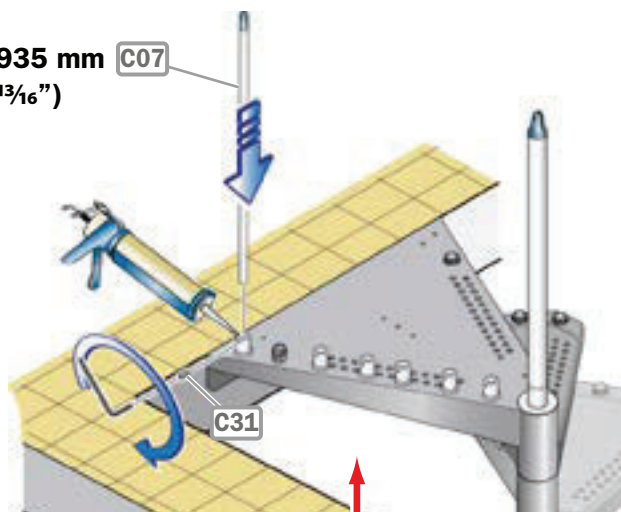

87

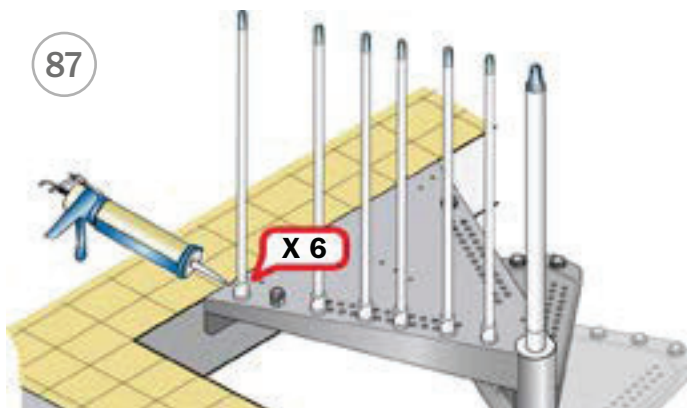

88

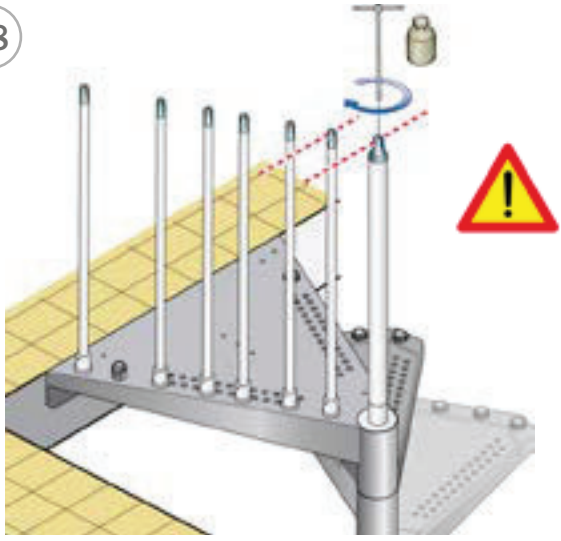

89

C07 H = 935 mm
(36 13/16")

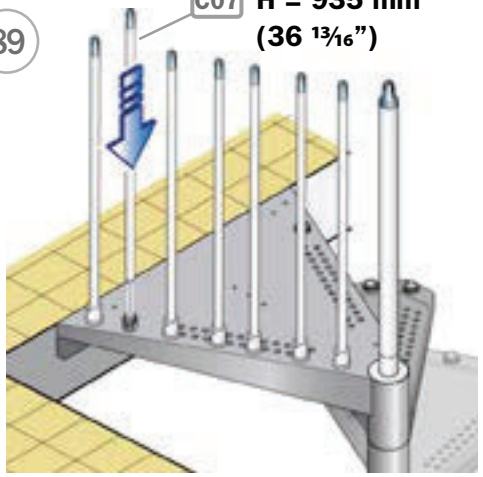

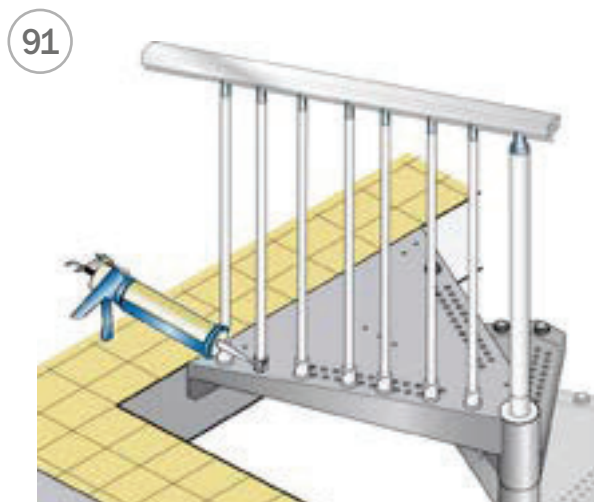
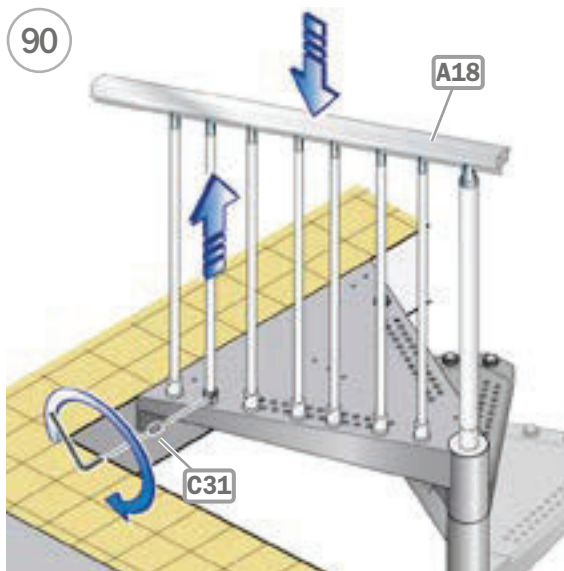

92

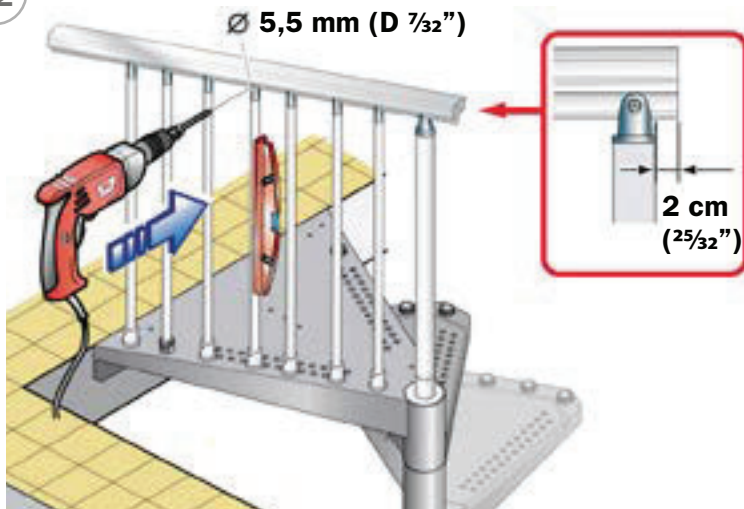

93

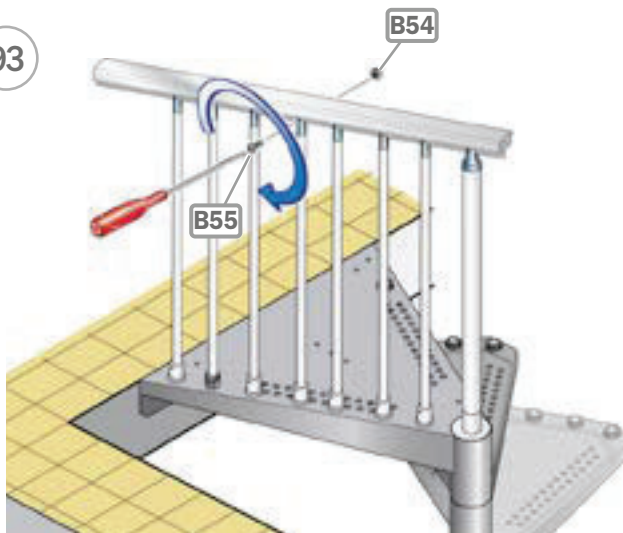

94

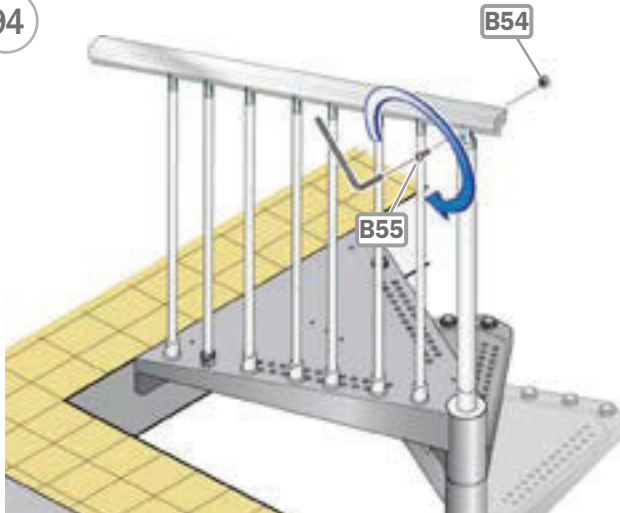

95

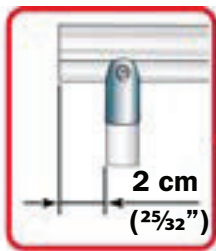

77

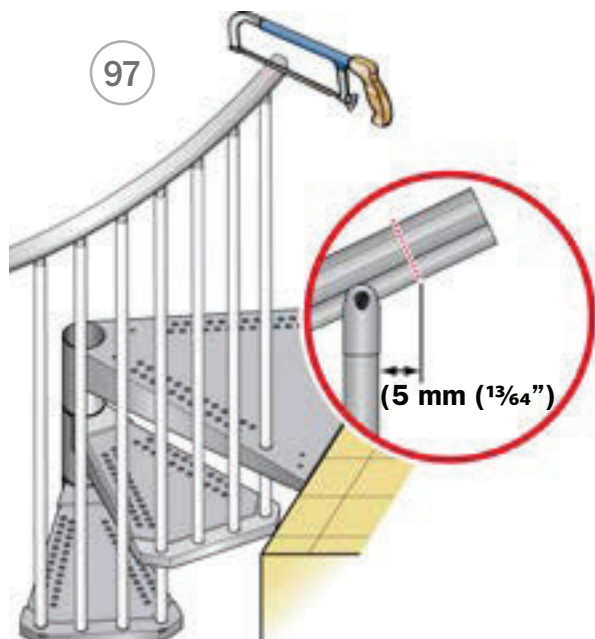
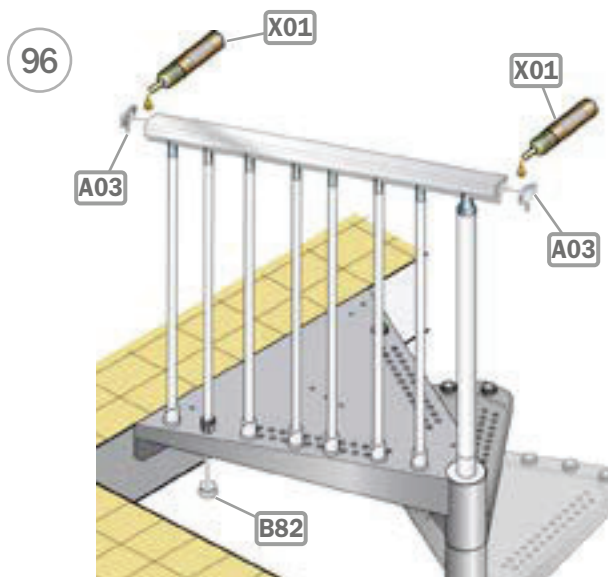

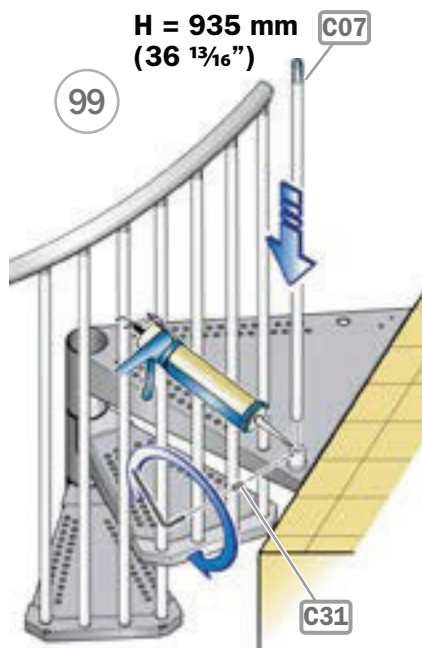
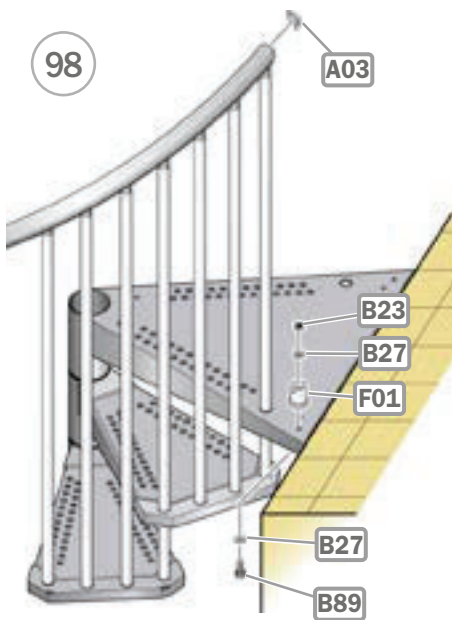

100

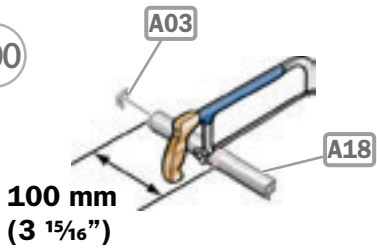

101

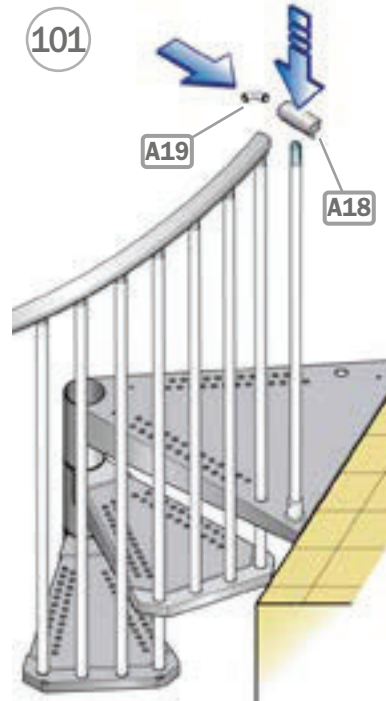

102

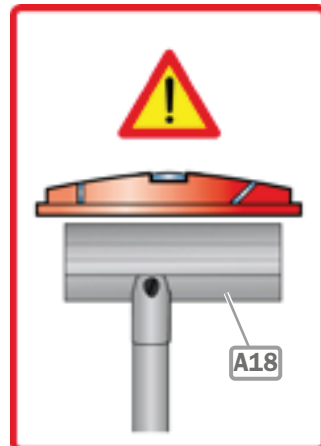
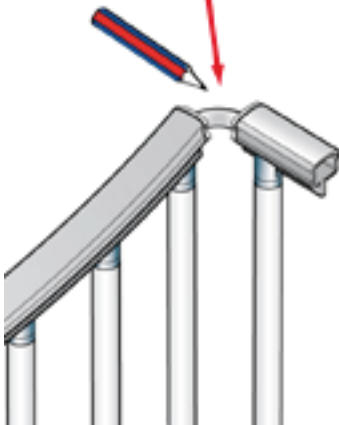

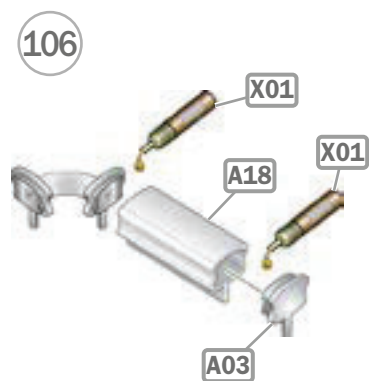
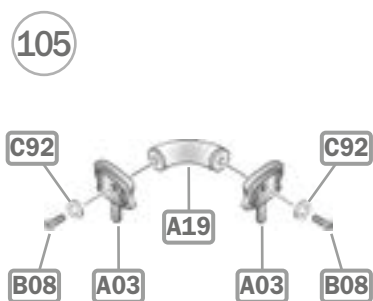
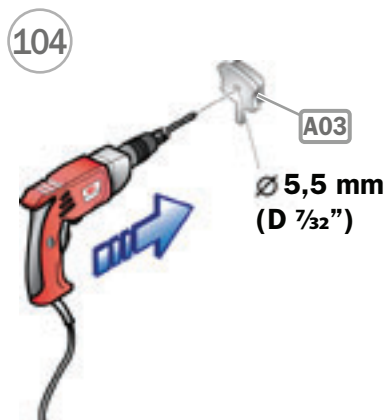
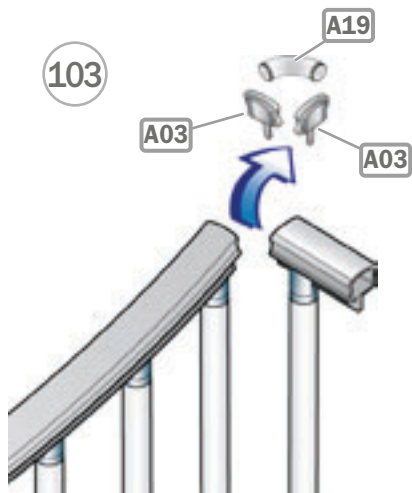

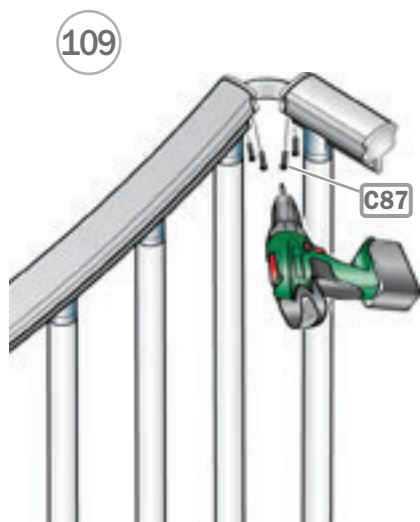
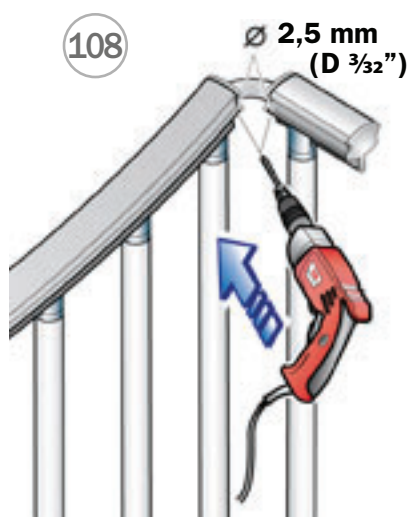
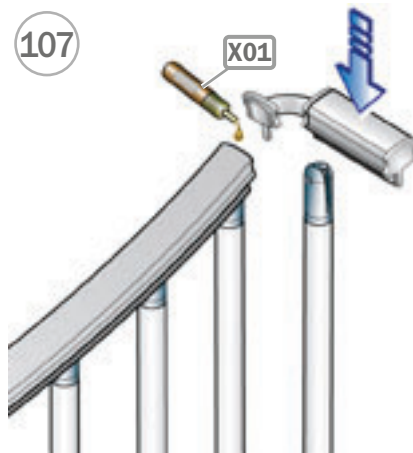

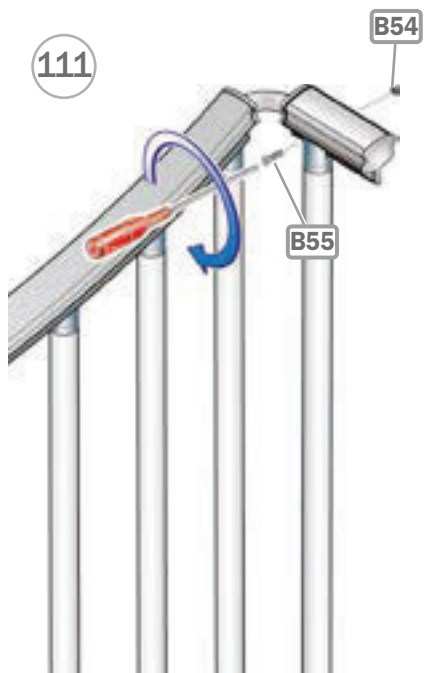

112

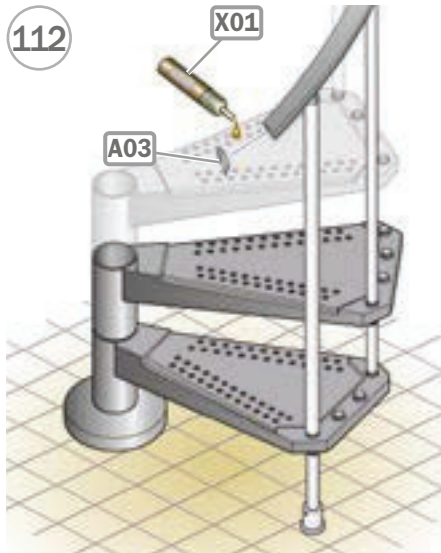

113 a

H = 1095 mm
(43 1/8")

Ø 120 cm
(D 47 1/4")

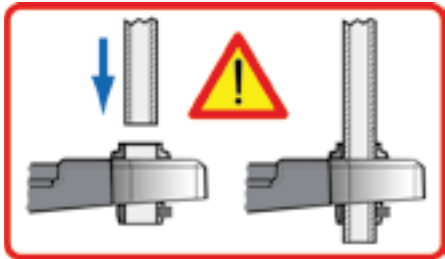

113—b

Ø 140 cm
(D 55 1/8")
Ø 160 cm
(D 63")

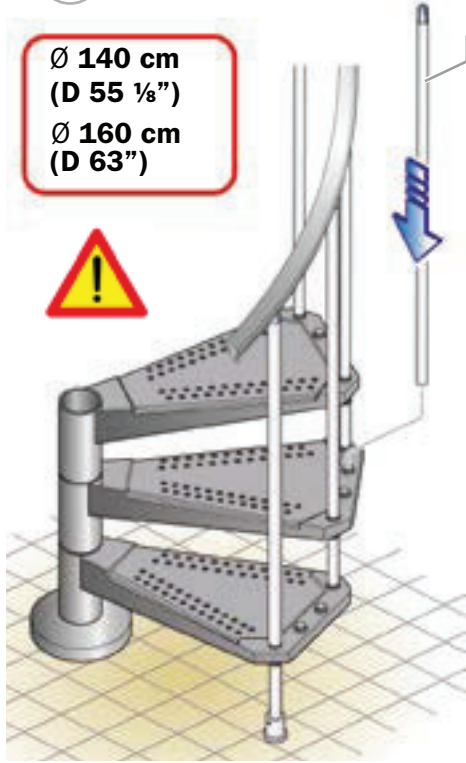

C07 H = 1130 mm (44 1/2")

114—b

H = 1060 mm (D 41 3/4")

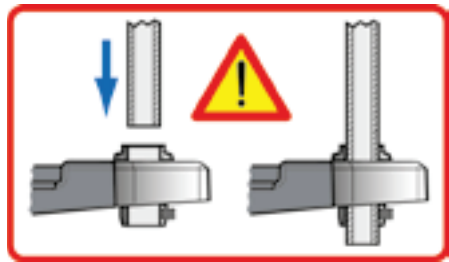
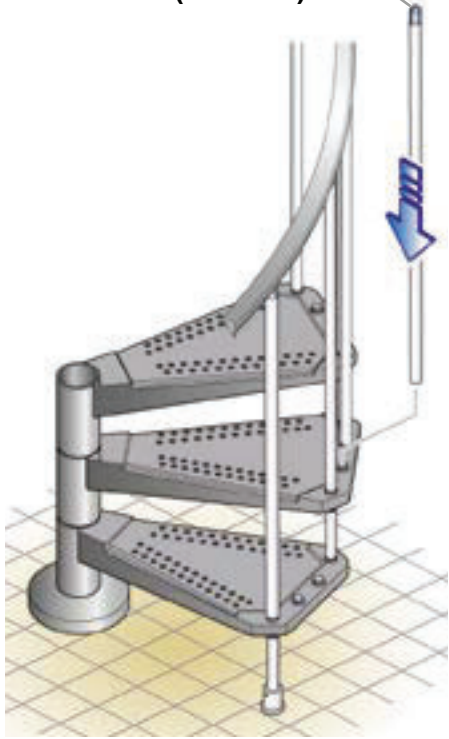

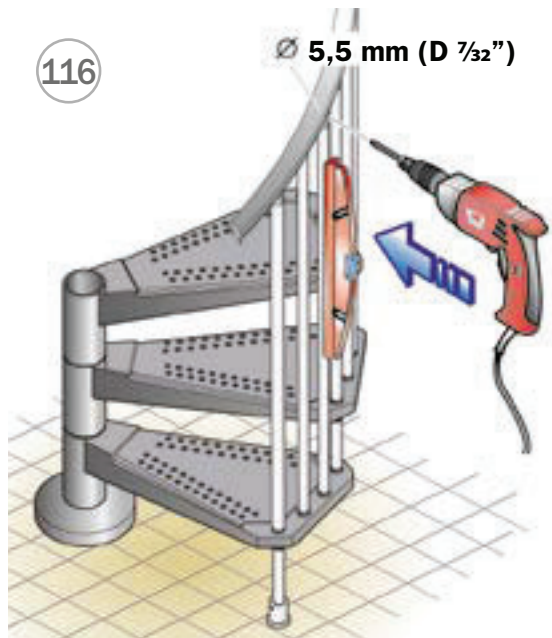
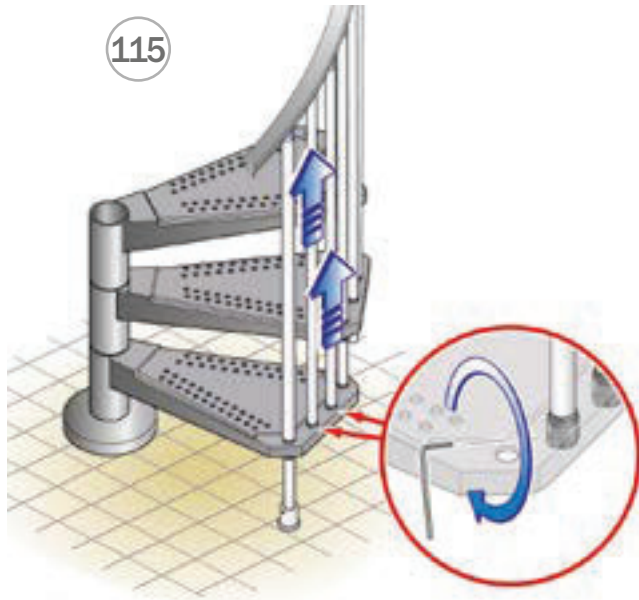

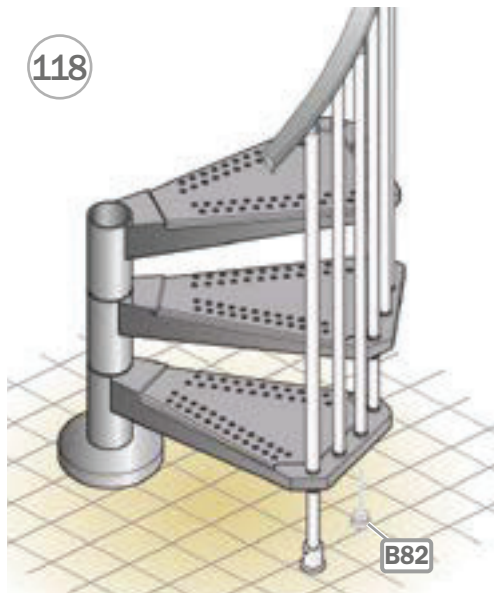
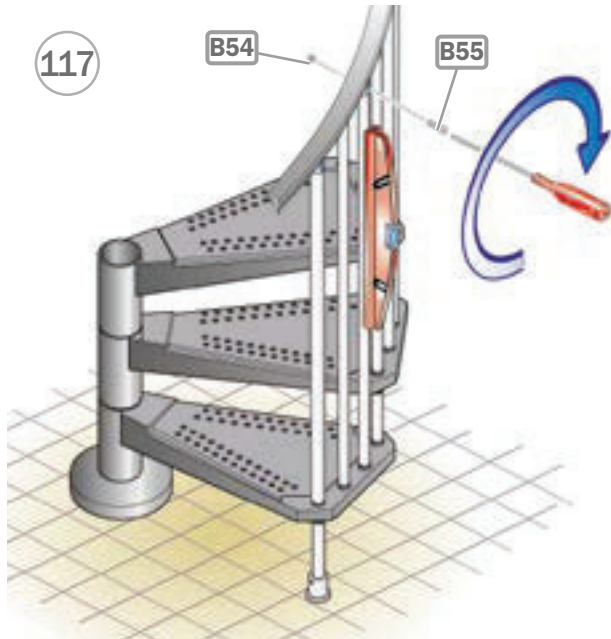

119

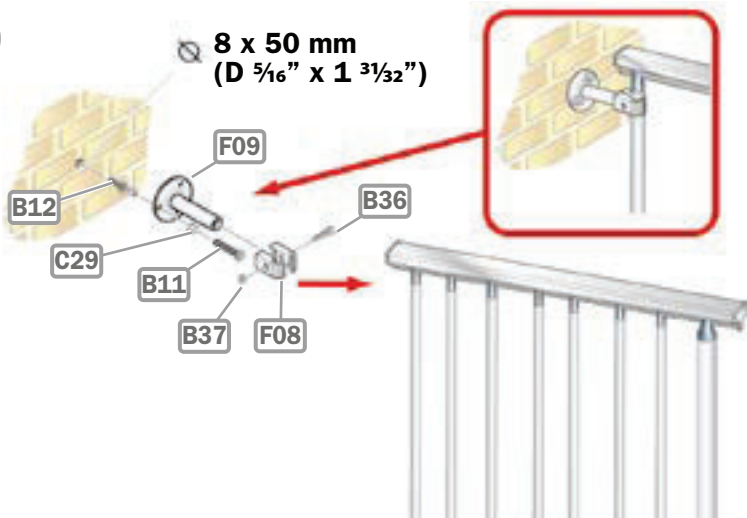

120

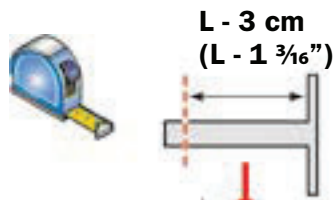
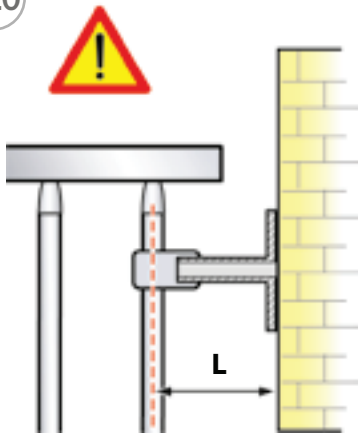

121



122

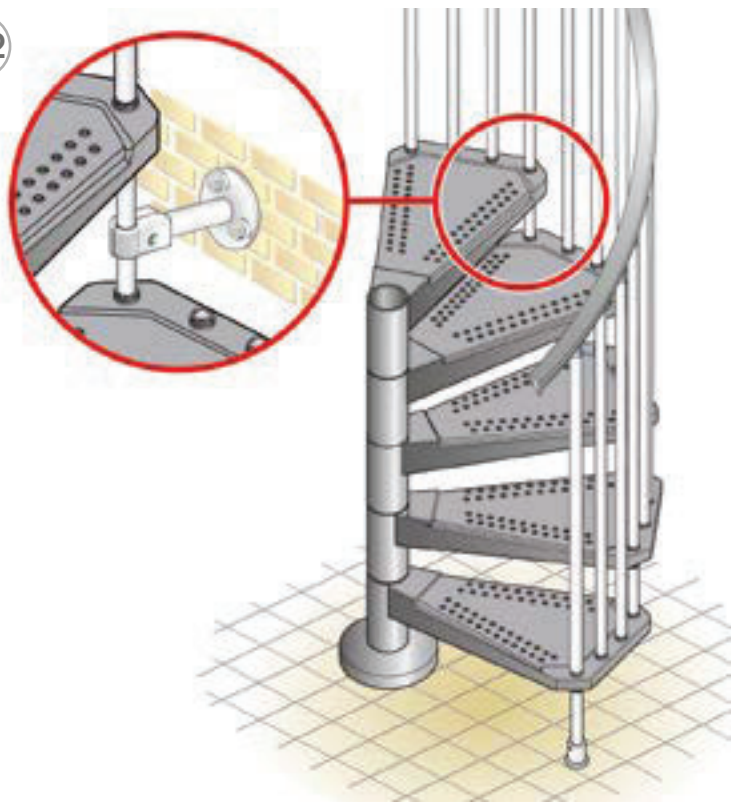

123

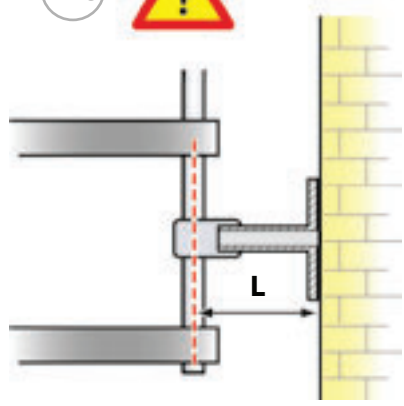

L - 3 cm
(L - 1 3/16")

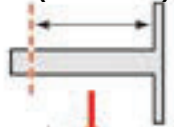



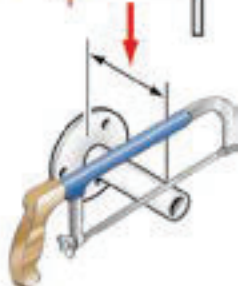

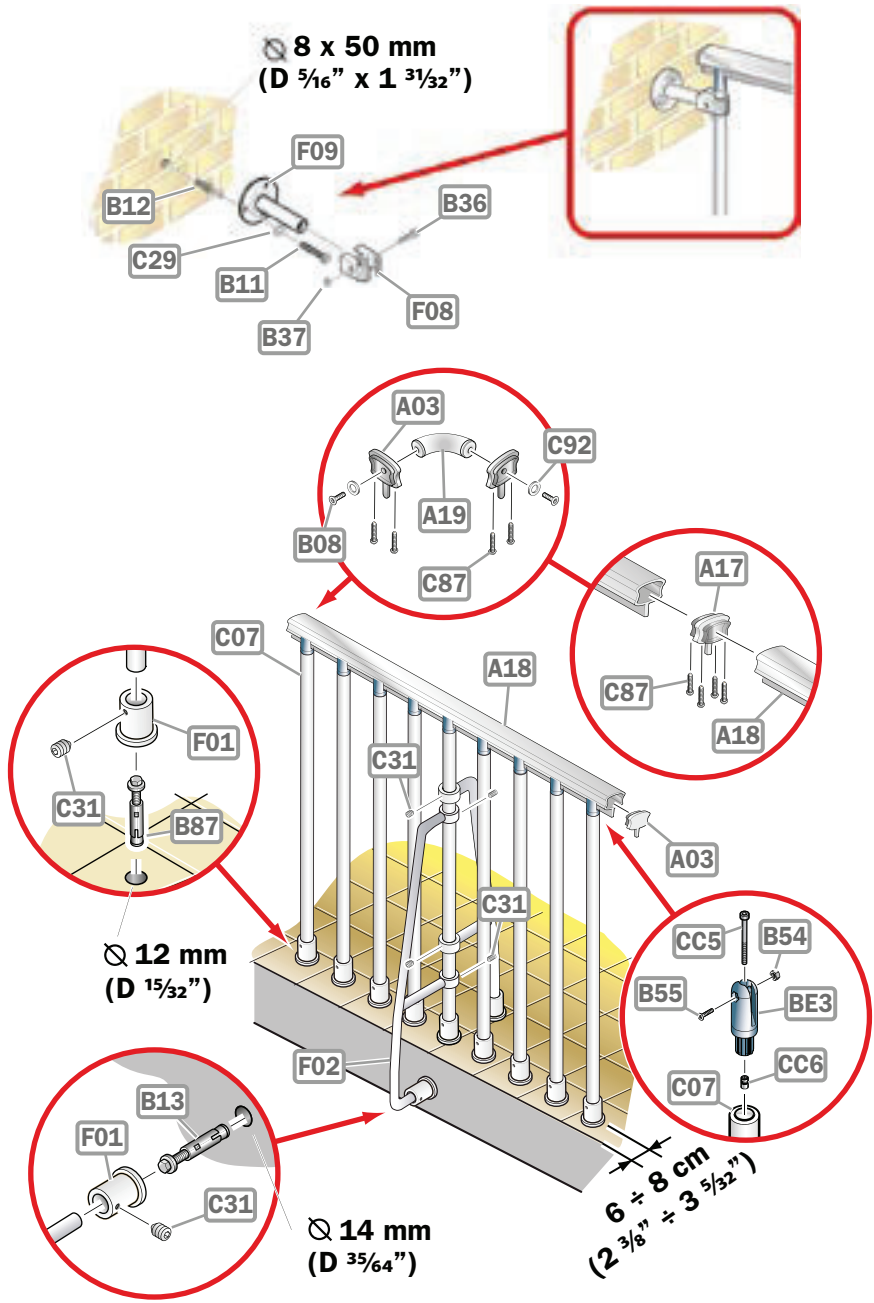

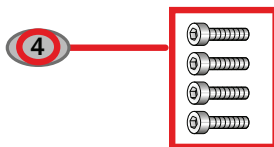

















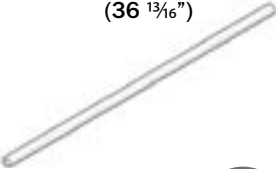

124







<p>A03</p>  <p>4</p>	<p>A17</p>  <p>1</p>	<p>A18</p>  <p>1</p>
<p>A19</p>  <p>1</p>	<p>B08</p>  <p>2</p>	<p>B11</p>  <p>M6 x 40 mm (M 15/64" x 1 37/64")</p> <p>3</p>
<p>B12</p>  <p>Ø 8 mm (D 5/16")</p> <p>3</p>	<p>B13</p>  <p>M8 mm (M 5/16")</p> <p>1</p>	<p>B36</p>  <p>M6 x 25 mm (M 15/64" x 63/64")</p> <p>1</p>
<p>B37</p>  <p>M6 mm (M 15/64")</p> <p>1</p>	<p>B54</p>  <p>10</p>	<p>B55</p>  <p>10</p>

<p>B87</p>  <p>10</p>	<p>BE3</p>  <p>10</p>	<p>C07 H = 935 mm (36 13/16")</p>  <p>10</p>
<p>C29</p>  <p>3</p>	<p>C31</p>  <p>6 x 6 mm (15/64" x 15/64")</p> <p>13</p>	<p>C87</p>  <p>8</p>
<p>C92</p>  <p>2</p>	<p>CC5</p>  <p>10</p>	<p>CC6</p>  <p>10</p>
<p>F01</p>  <p>11</p>	<p>F02</p>  <p>1</p>	<p>F08</p>  <p>2</p>
<p>F09</p>  <p>1</p>	<p>X01</p> 	

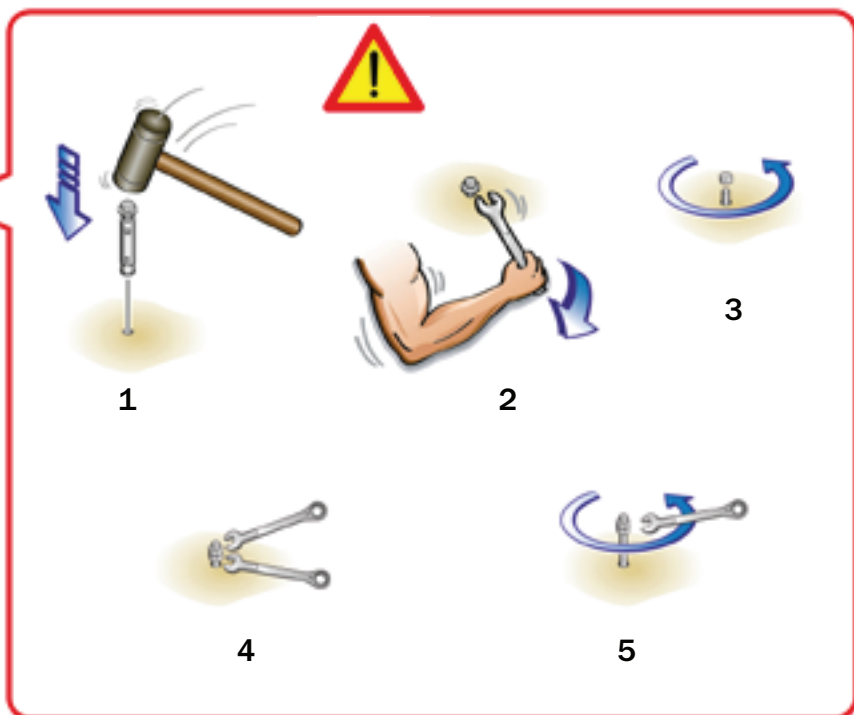
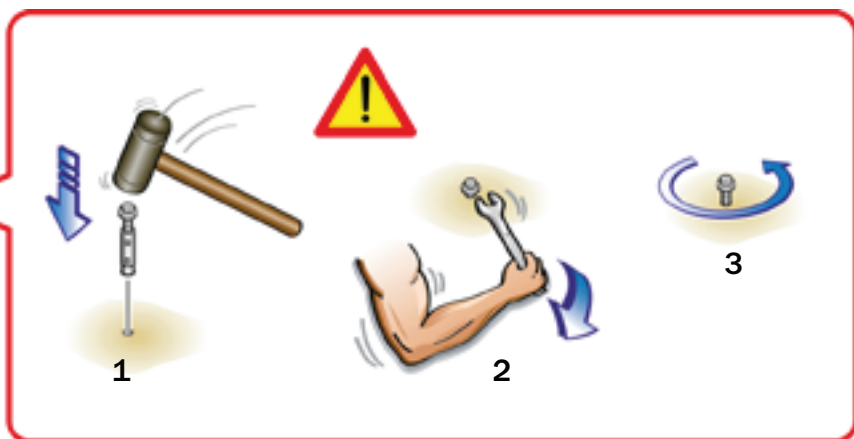



Italiano	DATI IDENTIFICATIVI DEL PRODOTTO
English	PRODUCT DETAILS
Deutsch	PRODUKTEIGENSCHAFTEN
Français	DONNÉES D'IDENTIFICATION DU PRODUIT
Español	DATOS DE IDENTIFICACIÓN
Português	DADOS DE IDENTIFICAÇÃO
Nederlands	KENMERKENDE PRODUCTGEGEVENS
Polski	DANE IDENTYFIKACYJNE PRODUKTU
Magyar	A TERMÉK AZONOSÍTÓ ADATAI
Română	DATELE DE IDENTIFICARE A PRODUSULUI
Русский	ИДЕНТИФИКАЦИОННЫЕ ДАННЫЕ ТОВАРА
Hrvatski	IDENTIFIKACIJSKI LIST PROIZVODA
Srpski	IDENTIFIKACIONSI LIST PROIZVODA
Česky	IDENTIFIKAČNÍ ÚDAJE O VÝROBKU
Slovensky	IDENTIFIKAČNÉ ÚDAJE O VÝROBKU
Slovenščina	IDENTIFIKACIJSKI LIST IZDELKA
Dansk	PRODUKTETS IDENTIFIKATIONSDATA
Svenska	PRODUKT DETALJER
Suomi	TIETOJA TUOTTEESTA
Eesti keel	TOOTE ANDMED
Türkçe	ÜRÜN AYRINTLARI
Norsk	PRODUKTINFORMASJON
한국어	제품 세부사항



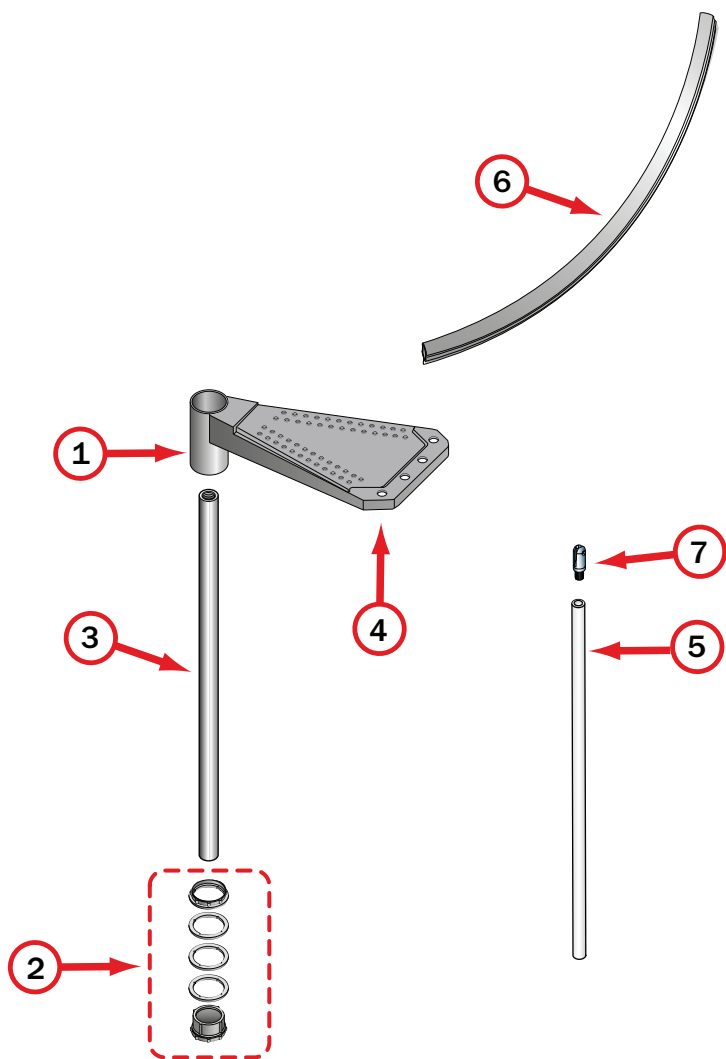

IT) dati identificativi del prodotto

denominazione commerciale: **ZNK**
tipologia: scala a chiocciola a pianta tonda

materiali impiegati

STRUTTURA

descrizione

composta da distanziali **(1)** in metallo (saldati al gradino) e spessori **(2)** in plastica impilati e compressi sul palo **(3)** centrale modulare

materiali

distanziali: Fe 360
spessori: nylon 66
palo: Fe 360 zincato

finitura

distanziali: zincatura a caldo

GRADINI

descrizione

gradini **(4)** in metallo circolari impilati sul palo **(3)** centrale

materiali

gradini: lamiera Fe 360

finitura

zincatura a caldo

RINGHIERA

descrizione

composta da colonnine **(5)** verticali in metallo fissate ai gradini **(4)** e da un corrimano **(6)** in PVC

materiali

colonnine: Fe 360
corrimano: PVC
fissaggi **(7)**: nylon

finitura

colonnine: zincatura a caldo

PULIZIA E MANUTENZIONE OBBLIGATORIA

Eseguire la pulizia della scala alla prima comparsa di macchie di sporco e depositi di polvere e periodicamente almeno ogni 6 mesi con panno morbido inumidito in acqua e detersivi specifici non abrasivi ed aggressivi. **NON** usare mai pagliette abrasive o in ferro. Pulire ed asciugare accuratamente dopo il lavaggio con un panno in microfibra al fine di eliminare gli aloni del calcare presente nell'acqua. Dopo circa 12 mesi dalla data di installazione, controllare il serraggio della viteria dei vari componenti. Al verificarsi di qualsiasi minimo malfunzionamento è obbligatorio effettuare una manutenzione straordinaria, da eseguire subito e a regola d'arte.

PRECAUZIONI D'USO

Evitare usi impropri e non consoni al prodotto. Eventuali manomissioni o installazioni non rispondenti alle istruzioni del produttore possono inficiare le conformità prestabilite del prodotto.

EN) product details

trade name: **ZNK**
type: spiral round plan staircase

materials used

STRUCTURE

description

composed of metal spacers **(1)** (welded to the tread) and plastic spacers **(2)** stacked and packed on the central modular pole **(3)**

materials

spacers: Fe 360
plastic spacers: nylon 66
pole: Fe 360 galvanized

finishing

spacers: hot dip galvanizing

TREADS

description

metal circular treads **(4)** stacked on the central pole **(3)**

materials

treads: plate Fe 360

finishing

hot dip galvanizing

RAILING

description

composed of vertical metal balusters **(5)** fixed to the treads **(4)** and of a PVC handrail **(6)**

materials

balusters: Fe 360
handrail: PVC
fixings **(7)**: nylon

finishing

balusters: hot dip galvanizing

OBLIGATORY CLEANING AND MAINTENANCE

Clean the treads as soon as dirt spots and dust deposits appear and at least every 6 months using a soft cloth moistened with water and specific non-abrasive and non-aggressive detergents. **NEVER** use abrasive scourers. After cleaning, thoroughly dry the surfaces with a microfibre cloth to remove the haloes that form because of the limestone in the water. Approximately 12 months from the date of installation, check tightness of the screws of the various components. Should even the smallest malfunction occur, it is obligatory to immediately and professionally carry out extraordinary maintenance.

USE PRECAUTION

Avoid any improper use that is not in accordance with the product. Possible violations or installations which don't comply with the providers instructions can invalidate the agreed product conformities.

DE) Produkteigenschaften

kommerzielle Bezeichnung: **ZNK**
Typologie: Spindeltreppe mit rundem Grundriss

verwendete Materialien

STRUKTUR

Beschreibung

bestehend aus Distanzhülsen (1) aus Metall (mit der Stufe verschweißt) und Distanzringen (2) aus Plastik um die Zentralsäule im Baukastensystem (3) herum gestapelt und komprimiert

Materialien

Distanzhülsen: Fe 360
Distanzringe: Nylon 66
Zentralsäule: Fe 360 verzinkt

Ausführung

Distanzhülsen: feuerverzinkt

STUFEN

Beschreibung

runde Stufen (4) aus Metall um die Zentralsäule (3) herum gestapelt

Materialien

Stufen: Fe 360 Blech

Ausführung

Feuerverzinkung

GELÄNDER

Beschreibung

bestehend aus auf den Stufen (4) befestigten, senkrechten Stäben (5) aus Metall und aus einem Handlauf (6) aus PVC

Materialien

Geländerstäbe: Fe 360
Handlauf: PVC
Befestigungsteile (7): Nylon

Ausführung

Geländerstäbe: feuerverzinkt

REINIGUNG UND VORGESCHRIEBENE INSTANDHALTUNG

Die Treppe sofort reinigen wenn Schmutzfl ecken und Staubansammlungen entstehen und sie mindestens alle 6 Monate mit einem weichen, mit Wasser und einem spezifischen, weder scheuernden, noch aggressiven Reinigungsmittel befeuchteten Lappen abwischen. NIEMALS scheuernde Eisenschwämme verwenden. Nach der Feuchtreinigung mit einem Mikrofasertuch sorgfältig nachtrocknen, um die Schlierenbildung durch kalkhaltiges Wasser zu vermeiden. 12 Monate nach der Montage das Anzugsmoment der Schrauben der verschiedenen Komponenten kontrollieren. Bei Auftreten einer noch so geringen Funktionsstörung muss unbedingt sofort eine fachgerechte außerordentliche Instandhaltung durchgeführt werden.

VORSICHTSMAßNAHMEN FÜR DIE ANWENDUNG

Die falsche und unangemessene Verwendung des Produkts vermeiden. Eventuelle Beschädigungen oder nicht der Montageanleitung des Herstellers gemässe Einrichtungen können die vorgegebene Produktkonformität für ungültig erklären.

FR) donnés d'identification du produit

denomination commerciale : **ZNK**
typologie: escalier en colimaçon à plan rond

matériaux utilisés

STRUCTURE

description

composée de entretoises (1) en métal (soudées à la marche) et cales (2) en plastique empilées et comprimées sur le pylône (3) modulaire central

matériaux

entretoises : Fe 360
cales : nylon 66
pylône : Fe 360 galvanisé

finition

cales : vernissage à chaud avec poudres époxy

MARCHES

description

marches (4) en métal circulaires empilées sur le pylône (3) central

matériaux

marches : tôle Fe 360

finition

galvanisation à chaud

GARDE-CORPS

description

composé de colonnettes (5) verticales en metal fixées aux marches (4) et d'une main courante en PVC (6)

matériaux

colonnettes : Fe 360
main courante : PVC
fixations (7) : nylon

finition

colonnettes : galvanisation à chaud

NETTOYAGE ET MAINTENANCE OBLIGATOIRE

Nettoyer les marches dès que des taches de saleté ou des dépôts de poussière apparaissent ; effectuer également un nettoyage périodique, tous les 6 mois, à l'aide d'un chiffon doux, humidifié d'eau et de détergents spécifiques non abrasifs et non agressifs. **NE JAMAIS** utiliser de la paille de fer abrasive. Après lavage, nettoyer et essuyer soigneusement avec un chiffon en microfibre, afin d'éliminer les auréoles provoquées par le calcaire contenu dans l'eau. Environ 12 mois après la date d'installation, contrôler le serrage des vis des différents composants. À la moindre défaillance, il est obligatoire d'effectuer immédiatement une maintenance corrective, dans les règles de l'art.

PRECAUTION D'UTILISATION

Eviter l'utilisation impropre et non conforme au produit. D'éventuelles alterations ou installations non correspondantes aux instructions du producteur peuvent invalider les conformités préétablies du produit.

ES) datos de identificación del producto

denominación comercial: **ZNK**

tipo: escalera de caracol de planta redonda

materiales empleados

ESTRUCTURA

descripción

compuesta por distanciadores **(1)** de metal (soldados al peldaño) y espaciadores **(2)** de plástico enfiladas y comprimidas en la columna **(3)** central modular

materiales

distanciadores: Fe 360

espaciadores: nylon 66

columna central: Fe 360 galvanizado

acabado

distanciadores: galvanización en caliente

PELDAÑOS

descripción

peldaños **(4)** de metal circulares enfilados en la columna **(3)** central

materiales

peldaños: chapa Fe 360

acabado

galvanización en caliente

BARANDILLA

descripción

compuesta por barrotes **(5)** verticales de metal fijados a los peldaños **(4)** y por un pasamanos **(6)** de PVC

materiales

barrotes: Fe 360

pasamanos: PVC

fijaciones **(7)**: nylon

acabado

barrotes: galvanización en caliente

LIMPIEZA Y MANTENIMIENTO OBLIGATORIO

Realizar la limpieza de la escalera en cuanto aparezcan manchas de suciedad y depósitos de polvo, y periódicamente al menos cada 6 meses, con un paño suave humedecido en agua y detergentes específicos no abrasivos ni agresivos. **NO** utilizar nunca lanas abrasivas o de hierro. Limpiar y secar bien después del lavado utilizando un paño de microfibra para eliminar las aureolas de cal dejadas por el agua. Transcurridos unos 12 meses desde la fecha de instalación, comprobar que los tornillos que fijan las distintas partes sigan bien apretados. Ante el menor defecto de funcionamiento, es obligatorio realizar un mantenimiento extraordinario según las reglas del arte.

PRECAUCIONES DE USO

Evitar usos impropios y no conformes con el producto. Eventuales manipulaciones o instalaciones que no cumplan con las instrucciones del fabricante pueden menoscabar las cualidades certificadas en las pruebas de conformidad a las que previamente fue sometido el producto.

PT) dados de identificação do produto

denominação comercial: **ZNK**

tipo: escada em caracol de planta redonda

materiais empregados

ESTRUTURA

descrição

constituída por separadores **(1)** de metal (soldados no degrau) e discos **(2)** de plástico empilhados e comprimidos no pilar **(3)** central modular

materiais

separadores: Fe 370

discos: nylon 66

pilar: Fe 370 zincado

acabamento

separadores: zincagem térmica

DEGRAUS

descrição

degraus **(4)** de metal circulares empilhados no pilar **(3)** central

materiais

degraus: chapa Fe 370 anilha 25/10

acabamento

zincagem térmica

BALAÚSTRE

descrição

constituída por hastes **(5)** verticais de metal fixas nos degraus **(4)** e por um corrimão **(6)** de PVC

materiais

hastes: Fe 370

corrimão: PVC

prendedores **(7)**: nylon

acabamento

hastes: zincagem térmica

LIMPEZA E MANUTENÇÃO OBRIGATÓRIA

Efetuar a limpeza da escada assim que surgirem manchas de sujidade e depósitos de pó e periodicamente pelo menos a cada 6 meses com um pano macio humedecido em água e detergentes específicos não abrasivos e agressivos. **NUNCA** usar palha de aço ou esfregões abrasivos. Limpar e secar cuidadosamente após a lavagem com um pano em microfibra para eliminar os halos de calcário presentes na água. Depois de aproximadamente 12 meses após a data de instalação, verifique se os parafusos e as porcas das várias peças estão apertados. Em caso de qualquer mínima avaria, é obrigatório efetuar uma manutenção extraordinária, imediatamente e de acordo com as regras.

PRECAUÇÕES NO USO

Evite usos impróprios, não em conformidade, do produto. Quaisquer alterações e instalações não correspondentes às instruções do fabricante podem prejudicar as conformidades preestabelecidas para o produto.

NL) kenmerkende productgegevens

commerciële benaming: **ZNK**
typologie: spiltrap met rond grondvlak

gebruikte materialen

STRUCTUUR

beschrijving

bestaande uit stalen trededragers (1) (aan de treden gelast) en kunststof opbouwsegmenten (2) die stapelsgewijs en samengedrukt aan de modulaire binnenspil (3) zijn bevestigd

materialen

trededragers: Fe 370
opbouwelementen: nylon 66
spil: Fe 370 verzinkt

afwerking

trededragers: thermisch verzinkt

TREDEN

beschrijving

cirkelvormige stalen treden (4) stapelsgewijs aan de binnenspil (3) bevestigd

materialen

treden: plaatstaal Fe 370 dikte 25/10

afwerking

thermisch verzinkt

TRAPLEUNING

beschrijving

bestaande uit verticale stalen spijlen (5) die aan de treden zijn bevestigd (4) en een PVC trapleuning (6)

materialen

spijlen: Fe 370
trapleuning: PVC
bevestigingsmateriaal (7): nylon

afwerking

spijlen: thermisch verzinkt

REINIGING EN VERPLICHT ONDERHOUD

Maak de ladder met een zachte doek bevochtigd met water en specifieke, niet-schurende en niet-agressieve reinigingsmiddelen schoon zodra de eerste vlekken en stofophoping zich voordoen. Verricht deze handeling elke 6 maanden. **GEEN** metaal- of schuursponsjes gebruiken. Na de reiniging schoonmaken en zorgvuldig met een microvezeldoek drogen om alle kalkvlekken te verwijderen. Controleer, na ongeveer 12 maanden na de installatiedatum, of het schroefwerk van de verschillende onderdelen nog goed vastzit. Verricht bij het kleinste gebrek onmiddellijk het buitengewone onderhoud volgens de technische normen.

VOORZORGSMAATREGELEN

Vermijd onjuist en ongeschikt gebruik van het product. Eventuele handelingen of installaties die niet volgens de aanwijzingen van de producent zijn uitgevoerd, kunnen de vooraf bepaalde conformiteit van het product wijzigen.

PL) dane identyfikacyjne produktu

nazwa handlowa: **ZNK**
typologia: schody spiralne na rzucie koła

wykorzystane materiały

STRUKTURA

opis

składa się z przekładek (1) z metalu (zespawanych ze stopniem) i podkładek (2) z plastiku, osadzonych i ściśniętych na środkowym stopniu (3) modułowym

materiały

przekładki: Fe 370
podkładki: nylon 66
słup: Fe 370 ocynkowany

wykończenie

przekładki: ocynkowanie na gorąco

STOPNIE

opis

stopnie (4) z metalu okrągłe lub wachlarzowe, ułożone na stopniu środkowym (3)

materiały

stopnie: blacha Fe 370 podkładka 25/10

wykończenie

ocynkowanie na gorąco

BALUSTRADA SCHODÓW

opis

składająca się z słupków (5) pionowych z metalu przymocowanych do stopni (4) i z poręczy (6) z PVC

materiały

słupki: Fe 370
poręcz: PVC
mocowania (7): nylon

wykończenie

słupki: ocynkowanie na gorąco

OBOWIĄZKOWE CZYSZCZENIE I KONSERWACJA

Czyścić schody w razie pojawienia się pierwszych plam brudu i osadów pyłu i okresowo, co najmniej raz na 6 miesięcy, przy użyciu miękkiej tkaniny zwilżonej wodą i środkami czyszczącymi nieposiadającymi właściwości ściernych i żrących. **NIGDY** nie stosować zmywaków ściernych lub metalowych. Dokładnie wyczyścić i po umyciu wysuszyć tkaniną z mikrofibry w celu usunięcia śladów wapnia zawartego w wodzie. Po około 12 miesiącach od daty montażu kontrolować dokręcenie części złącznych różnych elementów składowych. W razie nawet najmniejszej usterki, przeprowadzić konserwację nadzwyczajną, którą należy wykonać natychmiastowo i zgodnie z zasadami sztuki.

ZALECENIA DOTYCZĄCE UŻYTKOWANIA

Unikać nieprawidłowego użytkowania wyrobu, niezgodnego z jego przeznaczeniem. Ewentualne naruszenia warunków gwarancji lub instalowanie niezgodne z instrukcją producenta mogą skutkować unieważnieniem założonych własności wyrobu.

HU) a termék azonosító adatai

kereskedelmi megnevezés: **ZNK**
típus: kör alapú csigalépcső

felhasznált anyagok

SZERKEZET

leírás

fémről készült távtartókból **(1)** (a lépcsőfokokhoz vannak hegesztve) és műanyag távtartó hengerekből **(2)** áll melyek egymásba vannak helyezve és összenyomva a központi oszlopon **(3)**

anyagok

távtartók: 370 vas

távtartó hengerek: műanyag 66 nylon

oszloprúd: 370 horganyzott vas

borítás

távtartók: tűzi horganyzással készült borítás

LÉPCSŐFOKOK

leírás

fémről készült lépcsőfokok **(4)** körkörös az oszlopra erősítve **(3)**

anyagok

lépcsőfokok: 370-es vaslemezek, 25/10 vastagsággal

borítás

tűzi horganyzással készült borítás

KORLÁT

leírás

függőleges fém oszloprudakból áll **(5)** amiket a lépcsőre kell rögzíteni **(4)** valamint egy pvc korlátfából **(6)**

anyagok

oszloprudak: 370 vas

korlátkarfa: PVC

rögzítő elemek **(7)**: nylon

borítás

tartórudak: tűzi horganyzással készült borítás

KÖTELEZŐ TISZTÍTÁS ÉS KARBANTARTÁS

Tisztítsa meg a lépcsőket, amint szennyeződés vagy porlerakódás jelenik meg, de legalább 6 havonta, egy puha, nedves kendővel és az előírt, nem súroló hatású és nem agresszív tisztítószerrel. **SOHA NE** használjon súrolószereket! Tisztítást követően szárítsa meg a felületeket mikroszálas törölkendővel, hogy eltávolítsa a gyűrűket, amit a vízben lévő vízkő okoz. A telepítés napjától számított nagyjából 12 hónap múlva ellenőrizze az alkatrészek csavarjainak szorosságát. Ha a legkisebb üzemzavar előfordul, kötelező a soron kívüli karbantartás azonnali, szakszerű elvégzése.

HASZNÁLATI ELŐÍRÁSOK

A terméket kizárólag a rendeltetésének megfelelően kell használni. Esetleges rongálások, vagy a gyártó utasításainak nem megfelelő berendezés a termék stabilitását befolyásolhatják.

RO) datele de identificare a produsului

denumire comercială: **ZNK**

tipologie: scară elicoidală, cu formă rotundă în plan

materiale utilizate

STRUCTURA

descriere

compusă din distanțiere **(1)** din metal (sudate pe treaptă) și inele din plastic **(2)** fixate pe stâlpul central modular **(3)**

materiale

distanțiere: Fe 370

inele distanțiere: plastic 66

stâlp central: Fe 370, zincat

finisaje

distanțiere: zincare la cald

TREPTELE

descriere

trepte circulare din metal **(4)**, fixate pe stâlpul central **(3)**

materiale

trepte: tablă Fe 370, grosime 25/10

finisaje

zincare la cald

PARAPET

descriere

compus din coloane verticale din metal **(5)**, fixate pe trepte **(4)** și o mână curentă din PVC **(6)**

materiale

coloane: Fe 370

mână curentă: PVC

elemente de fixare **(7)**: plastic

finisaje

coloane: zincare la cald

CURĂȚAREA ȘI ÎNTREȚINEREA OBLIGATORIE

Curățați scara la prima apariție a petelor de murdărie și a depunerilor de praf și, periodic, cel puțin o dată la 6 luni cu o cârpă moale umezită cu apă și detergenți specifici neabrazivi și neagresivi. **NU** folosiți niciodată bureți metalici. Curățați și uscați bine după spălare cu o cârpă din microfibră pentru a elimina petele de calcar prezent în apă. După 12 luni de la data instalării, controlați strângerea șuruburilor diferitelor componente. La manifestarea celei mai mici defecțiuni, este obligatoriu să efectuați întreținerea extraordinară, imediat și conform regulilor de bună practică.

PRECAUȚII DE UTILIZARE

Evitați utilizarea improprie și necorespunzătoare a produsului. Eventualele intervenții sau instalări care nu corespund cu instrucțiunile producătorului ar putea anula datele de conformitate prestabilite pentru produs.

RU)

идентификационные данные товара

коммерческое название: **ZNK**

тип: винтовая лестница с круглым основанием

используемые материалы

КАРКАС

описание

состоит из металлических распорок **(1)**, приваренных к ступеням, и пластиковых прокладок **(2)**, надетых на центральную модульную опору **(3)** и зажатых на ней

материалы

распорки: Fe 370

прокладки: нейлон 66

опора: Fe 370, оцинкованная

отделка

распорки: горячая оцинковка

СТУПЕНИ

описание

круговые металлические ступени **(4)**, надетые на центральную опору **(3)**

материалы

ступени: металлическая пластина Fe 370, толщина 25/10

отделка

горячая оцинковка

ПЕРИЛА

описание

перила состоят из вертикальных металлических столбиков **(5)**, которые крепятся к ступеням **(4)**, и поручня **(6)** из поливинилхлорида

материалы

столбики: Fe 370

поручень: ПВХ

крепления **(7)**: полиамидная смола

отделка

столбики: горячая оцинковка

ОБЯЗАТЕЛЬНЫЕ ЧИСТКА И ОБСЛУЖИВАНИЕ

Выполняйте чистку лестницы при первом же появлении пятен грязи и налетов пыли и регулярно, примерно каждые 6 месяцев, протирайте мягкой влажной тряпкой со специальными моющими не абразивными и не агрессивными средствами. **НИКОГДА НЕ** используйте абразивные или металлические изделия. Вымойте и тщательно высушите после мойки тряпкой из микрофибры для удаления разводов извести, содержащейся в воде. Через 12 месяцев после монтажа проверьте плотность затяжки винтовых соединений на разных деталях. При выявлении какой-либо минимальной неисправности обязательно незамедлительно выполните экстренное обслуживание по правилам мастерства.

ПРЕДОСТОРОЖНОСТИ ПРИ ЭКСПЛУАТАЦИИ

Не допускайте ненадлежащего использования, не соответствующего типу продукции. Случайные повреждения или монтаж, выполненный не по инструкции производителя, могут привести к несоответствию продукции установленным требованиям.

HR)

identifikacijski list proizvoda

komercijalni naziv: **ZNK**

tip: spiralne stepenice

материјали израде

NOSIVA KONSTRUKCIJA

opis

sastavljena od razmaknih elemenata **(1)** zavarenih na gazišta **(2)** i plastičnih prstenova, sve postavljeno na modularni centralni stup **(3)**

materijali

razmakni elementi: Fe 370

razmakni prstenovi: najlon 66

stup: Fe 370 pocinčano

završna obrada

razmakni elementi: toplo cinčano

GAZIŠTA

opis

metalna gazišta **(4)** kružna i postavljena na centralni stup **(3)**

materijali

gazišta: lim Fe 370 debljine 25/10

završna obrada

toplo cinčano

OGRADA

opis

sastavljena od vertikalnih metalnih **(5)** stupića spojenih sa gazištima **(4)** i pvc rukohvatom **(6)**

materijali

stupići: Fe 370

rukohvat: PVC

spojni elementi **(7)**: nylon

završna obrada

stupići: toplo cinčano

OBAVEZNO ČIŠĆENJE I ODRŽAVANJE

Stepenice treba očistiti čim se pojave prve mrlje prljavštine i naslage prašine te periodično, najmanje svakih 6 mjeseci, mekanom krpom navlaženom u vodi i specifičnim, neabrazivnim i neagresivnim sredstvima za čišćenje. **NEMOJTE** nikad rabiti abrazivne ili željezne jastučiće za ribanje. Nakon pranja očistite i temeljito osušite krpom od mikrovlakana kako biste uklonili mrlje od kamenca prisutnog u vodi. Nakon otprilike 12 mjeseci od postavljanja kontrolirajte zategnutost vijčanih pričvršćenja raznih komponenata. Ako dođe do bilo kakve i najmanje neispravnosti, obavezno i odmah treba izvršiti izvanredno održavanje prema pravilima struke.

NAPOMENE ZA KORIŠTENJE

Izbjegavati neprikladno korištenje proizvoda. Nepridržavanje uputstava za montažu može utjecati na predviđene karakteristike proizvoda.

SR)

identifikacioni list proizvoda

komercijalni naziv: **ZNK**

tip: spiralne stepenice

materijali izrade

NOSEĆA KONSTRUKCIJA

opis

sastavljena od razmaknih elemenata (1) zavarenih na gazišta (2) i plastičnih prstenova, sve postavljeno na modularni centralni stub (3)

materijali

razmakni elementi: Fe 370

razmakni prstenovi: najlon 66

stub: Fe 370 pocinčano

završna obrada

razmakni elementi: toplo cinčano

GAZIŠTA

opis

metalna gazišta (4) kružna ili lepezasta postavljena na centralni stub (3)

materijali

gazišta: lim Fe 370 debljine 25/10

završna obrada

toplo cinčano

OGRAĐA

opis

sastavljena od vertikalnih metalnih (5) stubića spojenih s gazištima (4) i pvc rukohvatom (6)

materijali

stubići: fe 370

rukohvat: PVC

sastavni elementi (7): nylon

završna obrada

stubići: toplo cinčano

OBAVEZNO ČIŠĆENJE I ODRŽAVANJE

Očistite stepenice čim se pojave znaci prljavštine i naslage prašine, a najmanje jednom u 6 meseci, i to mekom krpom navlaženom vodom i posebnim deterdžentom koji ne sme biti ni abrazivan ni agresivan. NIKADA ne koristite žicu za čišćenje. Nakon čišćenja, pažljivo osušite površine krpom od mikrofibera kako biste otklonili okugle mrlje koje se stvaraju zbog kamenca u vodi. Nakon otprilike 12 meseci od dana instaliranja, proverite da li su šrafovi na raznim komponentima zategnuti. Ako primetite i namjanji problem, odmah se mora izvršiti vanredno održavanje od strane profesionalnog osoblja.

NAPOMENE ZA KORIŠĆENJE

Izbegavati neprikladno korišćenje proizvoda. Nepridržavanje uputstvu za montažu može da utiče na predviđene karakteristike proizvoda.

CS)

identifikační údaje o výrobku

obchodní označení: **ZNK**

typologie: točité schodiště s kulatým půdorysem

použité materiály

STRUKTURA

popis

složené z kovových rozpěr (1) (sletovaných ke schodku) a z plastové tloušťky (2) navršené a sliisované na středovém modulovém sloupu (3)

materiály

rozpěry: Fe 370

tloušťky: nylon 66

sloup: Fe 370 pozinkovaný

povrchová úprava

rozpěry: pozinkované za tepla

SCHODKY

popis

točité kovové schody (4) navršené na středovém sloupu (3)

materiály

schodky: ocelový plech Fe 370 tloušťka 25/10

povrchová úprava

pozinkování za tepla

ZÁBRADLÍ

popis

složené z kovových vertikálních příček (5) připevněných ke schodům (4) a z jednoho madla (6) v PVC

materiály

příčky: Fe 370

madlo: PVC

upevnění (7): nylon

povrchová úprava

příčky: pozinkované za tepla

POVINNÉ ČIŠTĚNÍ A ÚDRŽBA

Očistěte závitý jakmile se objeví nečistoty a usazený prach, nejméně však jednou za 6 měsíců. Čištění proved'te měkkým hadrem namočeným do vody s neabrazivním a neagresivním čistícím prostředkem. NIKDY nepoužívejte drátěnky. Po vyčištění důkladně otřete hadrem z mikrovláken, aby se odstranily odlesky způsobené vápnem ve vodě. Asi po 12 měsících po instalaci, zkontrolujte utažení šroubů všech součástí. Pokud dojde k jakémukoliv i malé poruše, je nezbytné okamžitě a profesionálně provést mimořádnou údržbu.

BEZPEČNOSTNÍ POKYNY

Vyhýbat se nesprávnému a nevhodnému použití výrobku. Eventuální poškození nebo instalace neodpovídající instrukcím výrobce mohou porušit předem sjednané kvality výrobku.

SK)

identifikačné údaje o výrobku

obchodný názov: ZNK

typ: točité schodisko s kruhovou základňou

použité materiály

KONŠTRUKCIA

opis

skladá sa z kovových rozpiere (1) (privarených na schodiskový stupeň) a umelohmotných rozperných krúžkov (2) uložených nad sebou a stlačených na stredovej modulevej tyči (3)

materiály

rozpery: Fe 370

rozperné krúžky: nylon 66

tyč: Fe 370 s pozinkovaním

povrchová úprava

rozpery: zinkovanie za tepla

SCHODISKOVÉ STUPNE

opis

točité kovové schodiskové stupne (4) uložené nad sebou na stredovej tyči (3)

materiály

schodiskové stupne: plech Fe 370 hrúbka 25/10

povrchová úprava

zinkovanie za tepla

ZÁBRADLIE

opis

skladá sa zo zvislých kovových stĺpikov (5) upevnených k schodiskovým stupňom (4) a PVC madla (6)

materiály

stĺpiky: Fe 370

madlo: PVC

upevnenia (7): nylon

povrchová úprava

stĺpiky: zinkovanie za tepla

POVINNÉ ČISTENIE A ÚDRŽBA

Závity vyčistíte hneď, ako sa na nich objavia známky znečistenia alebo nánosy prachu a aspoň každých 6 mesiacov používania pomocou vlhkej utierky a špecifických, neabrazívnych a neagresívnych čistiacich prostriedkov. NIKDY nepoužívajte abrazívne drôtenky.

Po vyčistení dokonale vysušte povrch utierkou z mikro vlákien, aby sa odstránili zvyšky vodného kameňa, ktorý sa tvorí prítomnosťou vápnika vo vode. Približne 12 mesiacov od dátumu inštalácie skontrolujte, či sú dotiahnuté skrutky na všetkých komponentoch. Keď sa vyskytne sebemenšia porucha, povinne sa musí okamžite a profesionálne vykonať špeciálna údržba.

OPATRENIA PRE POUŽÍVANIE

Nepoužívajte spôsobom, ktorý nie je pre výrobok vhodný a primeraný. V dôsledku neodborných zásahov alebo montáže, ktoré nie sú v súlade s pokynmi výrobcu, môžu byť stanovené zhody výrobku neplatné.

SL)

identifikacijski list izdelka

komercialni opis: ZNK

tip: špiralne stopnice

sestava

NOSILNA KONSTRUKCIJA

opis

sestavljeno iz nastavljenih elementov (1) privarjenih na stopne plošče (2) in plastičnih obročkov distančnikov, vse skupaj postavljeno na modularni centralni steber (3)

materiáli

nastavljeni elementi: Fe 370

nastavljeni obročki distančniki: nylon 66

stebriček: Fe 370 pocinkan

končna obdelava

nastavljeni elementi: toplo cinkano

STOPNICE

opis

kovinske stopnice (4) okroglo postavljene na centralni steber (3)

materiáli

stopnice: pločevina Fe 370 debline 25/10

končna obdelava

stopnice: lakirana in zapčena epoksidna barva v prahu

OGRAJA

opis

sestavljena iz vertikalnih kovinskih (5) stebričkov pritrjenih na stopnico (4) in pvc ročajem (6)

materiáli

stebrički: Fe 370

ročaj: PVC

spojni elementi (7): nylon

končna obdelava

stebrički: toplo cinkani

OBVEZNO ČIŠČENJE IN VZDRŽEVANJE

Stopnice očistite ob prvem pojavu madežev umazanije in nakopičenega prahu, občasno pa najmanj na vsakih 6 mesecev, z mehko vlažno krpo, ki ste jo namočili v vodi in posebnem čistilnem sredstvu, ki ni agresivno in ne abrazívno. NIKOLI ne uporabljajte abrazívnych ali železnih krtáč. Po pranju pozorno očistite in osušite površino s krpo iz mikrovlačen in tako odstranite madeže, ki nastanejo zaradi apnenca v vodi. Po približno 12 mesecih od datuma namestitve preverite prítovitost vijakov na različnih sestavnih delih. Če ugotovite, da je prišlo do najmanjšega slabega delovanja, morate obvezno izvesti izredno vzdrževanje, ki ga je potrebno opraviti takoj in po pravilih stroke.

NAPOTKI ZA UPORABO

Nepravilna uporaba izdelka, neupoštevanje navodil za montažo lahko vpliva na predvidene karakteristike izdelka.

DA) produktets identifikationsdata

handelsbetegnelse: **ZNK**

type: vindeltrappe med rundt skema

brugte materialer

STRUKTUREN

beskrivelse

strukturen består af afstandsstykker (1) i metal (svejset på trinene) og plastikpakninger (2) indsat oven på hinanden og komprimeret på den midterste modulstolpe (3)

materialer

afstandsstykker: Fe 370

pakninger: nylon 66

stolpe: Fe 370 forzinket

finish

afstandsstykker: zinkbad

TRIN

beskrivelse

cirkulære metaltrin (4) indsat oven på hinanden på centralstolpen (3)

materialer

trin: metalplade Fe 370 tykkelse 25/10

finish

zinkbad

GELÆNDER

beskrivelse

gelænderet består af små lodrette metalstolper (5) fastsat til trinene (4) og en håndliste i PVC (6)

materialer

små stolper: Fe 370

håndliste: PVC

fikseringer (7): nylon

finish

små stolper: zinkbad

RENGØRING OG PÅBUDT VEDLIGEHOLDELSE

Trappen skal rengøres når de første tegn på tilsmudsning og af støvaflejringer fremkommer, og i hvert fald regelmæssigt for hver 6. måned med en blød klud vædet i vand og specifikke ikke ætsende eller aggressive rengøringsmidler. Der må ALDRIG bruges skure- eller stålsvampe. Rengør og tør omhyggeligt med en mikrofiberklud efter vask for at fjerne kalkaflejringerne, der findes i vandet. Efter ca. 12 måneder fra installationsdatoen, kontrolleres fikseringen på de forskellige komponenters skruer. I tilfælde af en hvilken som helst fejlfunktion, er det påbudt at udføre en ekstraordinær vedligeholdelse, der bør udføres omgående og i overensstemmelse med bedste praksis.

BRUGSHENVISNINGER

Undgå at bruge produktet forkert. Eventuelle fejlgreb eller installationer, som ikke er i overensstemmelse med producentens instruktioner, kan svække produktets fastsatte egenskaber.

SV) produkt detaljer

varunavn: **ZNK**

typ: rund spiral trappa

anvånt material

KONSTRUKTIONEN

beskrivelse

sammansatt av avståndsbrickor (1) i metall (ihopmonterade medi steget) och avståndsbrickor (2) i plast som man trår i och pressar ner över mitt (3) pelaren

material

avståndsdelar: Fe 370

avståndsbrickor: nylon 66

mittpelare: Fe 370 galvaniserad

ytbehandling

avståndsdelar: varm galvanisering

STEG

beskrivelse

solfjåderformade steg (4) i metall som man trår över mitt (3) pelaren

material

stegen: plåt Fe 370 tjocklek 25/10

ytbehandling

varm galvanisering

RÅCKE

beskrivelse

sammansatt av verticala (5) metall ståndare monterade på stegen (4) och av en handledare (6) i PVC

material

ståndare: Fe 370

handledare: PVC

monteringsbeslag (7): nylon

ytbehandling

ståndare: varm galvanisering

NÖDVÄNDIG RENGÖRING OCH UNDERHÅLL

Rengör trappan vid första smutsfläck eller när damm samlas, och regelbundet minst var 6:e månad. Rengör med en trasa fuktad med vatten och lämpligt rengöringsmedel som inte är slipande eller frätande. Använd aldrig slipande svampar eller stålull. Rengör och torka noggrant efter rengöring med en mikrofiberduk för att undvika kalkfläckar från vattnet. Kontrollera åtdragningen av skruvarna för de olika komponenterna efter 12 månader. Vid varje typ av felfunktion är det obligatoriskt att utföra ett extra underhåll. Detta ska utföras omedelbart och på ett yrkesmannamässigt sätt.

FÖRSIKTIGHETSÅTGÄRDER

Unvik felaktig och en ej överensstämmande användning av produkten. Eventuell överanvändning eller en installation som inte följer anvisningarna av produkten kan medföra att produktens garantier blir ogiltiga.

FI) tietoja tuotteesta

kaupallinen nimi: **ZNK**
porrastyyppi: kierreportaat, joissa pyöreä pohjapiirros

käytetyt materiaalit

RAKENTEESSA

selostus

rakenteeseen kuuluu metalliset välikelevyt (**1**) (jotka on hitsattu kiinni askelmaan), sekä päällekkäin asetetut muoviset sovittelementit (**2**) jotka on puristettu kiinni rakenneyksiköistä koostuvaan keskuspylvääseen (**3**)

materiaalit

välikelevyt: Fe 370
sovittelementit:nailon 66
pylväs: Fe 370, sinkkity
pintakäsittely
välikelevyt: kuumasinkitys

ASKELMAT

selostus

metalliaskelmat (**4**) jotka on kiinnitetty ympyränmuotoisesti keskuspylvääseen (**3**)

materiaalit

askelmat: rautalevyä Fe 370, paksuus 25/10
pintakäsittely
kuumasinkitys

KAIDE

selostus

rakenteeseen kuuluu metalliset pystytolpat (**5**) jotka on kiinnitetty askelmiin (**4**) sekä käsijohde (**6**) PVC muovia

materiaalit

tolpat: Fe 370
käsijohde: PVC
kiinnikkeet (**7**): nailon
pintakäsittely
tolpat: kuumasinkitys

PAKOLLINEN PUHDISTUS JA YLLÄPITO

Huolehdi portaiden puhdistuksesta ensimmäisten likatahrojen tai pölyjäämien ilmestyessä sekä säännöllisin väliajoin vähintään joka 6. kuukausi liinalla, joka on kostutettu miedon hankaamattoman pesuaineen ja veden muodostamassa liuoksessa. ÄLÄ koskaan käytä hankaavia tai metallisia sieniä. Puhdista ja kuivaa huolellisesti pesun jälkeen mikrokuituliinalla, jotta poistetaan vesijäämien aikaansaamat kalkkiläikät. Noin 12 kuukauden kuluttua asennuksesta tarkista, että kaikki eri osien ruuvit ja mutterit ovat tiukalla. Mikäli havaitaan pienikin toimintahäiriö, on pakollista suorittaa ennakoimaton huolto, välittömästi ja tarvittavat toimenpiteet kunnolla suorittaen.

VAROTUKSET

Vältä asiatonta käyttöä ja käyttöä, joka ei vastaa tuotteen käyttötarkoitusta. Mikäli tuotetta on muunneltu tai se on asennettu ohjeiden vastaisesti, saattaa tuotteen yhdenmukaisuus säädettyjen normien kanssa joutua vaaranalaiseksimität für ungültig erklären.

ET) toote andmed

tootenimet: **ZNK**
tüüp: tüüp: ümara põhiplaaniga keerdtrepp

kasutatud materjalid

STRUKTUUR

kirjeldus

koosneb metallist (astme külge keevitatud) vahetükkidest (**1**) ja plastist vahetükkidest (**2**), mis laotakse tihedalt kokkusurutuna ülestikku moodulitest keskpsti (**3**) otsa

materjalid

metallist vahetükid: Fe 370
plastist vahetükid: nailon-66
post: tsingitud Fe 370
viimistlus
metallist vahetükid: kuumtsingitud

ASTMED

kirjeldus

ringikujuliselt paiknevad metallastmed (**4**), mis laotakse keskpsti (**3**) otsa

materjalid

astmed: Fe 370 plaat paksusega 25/10
viimistlus
kuumtsingitud

PIIRE

kirjeldus

koosneb vertikaalsetest metallpostidest (**5**), mis on kinnitatud astmete (**4**) külge, ja PVC'ist käsipuust (**6**)

materjalid

postid: Fe 370
käsipuu: PVC
kinnitused (**7**): nailon
viimistlus
piirdepostid: kuumtsingitud

KOHUSTUSLIK PUHASTAMINE JA HOOLDUS

Puhastage keermed kohe saasta ja tolmu ilmnenisel ja vähemalt kord iga 6 kuu järel, kasutades selleks vees niisutatud pehmet lappi ning spetsiaalset mitteabrsiivset ja mittesöövitavat puhastusvahendit. ÄRGE kasutage abrasiivseid vahendeid. Pärast puhastamist kuivatage pinnad hoolikalt mikrokiust lapiga, et eemaldada vees sisalduvast paekivist tekkiv hägu. Umbes 12 kuud pärast paigaldust kontrollige erinevate osade kruvide pingutusmomenti. Ka kõige väiksema talitlushäire korral on vaja kohe teha professionaalne erakorraline hooldus.

ETTEVAATUST KASUTAMISEL

Vältige toote ebaõiget ja ebasihpärast kasutamist. Võimalikud muudatused või paigaldus, mis ei vasta tootja poolt sätestatule, võivad tühistada tootel algselt olemasoleva vastavuse normatiividele.

TR) ürün ayrıntıları

ticari adı: **ZNK**
tip: yuvarlak spiral merdiven

kullanılan malzemeler

YAPI

açıklama
merkezi modüler direğe (3) istiflenmiş ve paketlenmiş metal (basamağa kaynak yapılmış) (1) ve plastik ara levhalarından (2) oluşur
malzemeler
ara levhalar: Fe 370
plastik ara levhaları: nylon 66
direk: Galvanize Fe 370
kaplama
ara levhaları: sıcak galvanize

BASAMAKLAR

açıklama
merkezi direğe (3) istiflenmiş metal dairesel basamaklar (4)
malzemeler
basamaklar: plaka Fe 370 kalınlık 25/10
kaplama
sıcak galvanize

KORKULUK

açıklama
PVC trabzan (6) ile basamaklara (4) sabitlenmiş metal dikey korkuluklardan (5) oluşur
malzemeler
korkuluklar: Fe 370
trabzan: PVC
bağlantı parçaları (7): nylon
kaplama
korkuluklar: sıcak galvanize

TEMİZLİK VE BAKIM ZORUNLULUĞU

Su ve özel aşındırıcı olmayan ve zararsız deterjanlar ile ıslatılmış yumuşak bir bez kullanarak pislikler ve toz kalıntıları görünür görünmez ve en azından her 6 ayda bir dışleri temizleyin. ASLA aşındırıcı bulaşık telleri kullanmayın. Temizledikten sonra, sudaki kireçten dolayı oluşan hataları ortadan kaldırmak için mikrofiber bir bez ile yüzeyleri iyice kurulayın. Kurulum tarihinden yaklaşık olarak 12 ay sonra, muhtelif bileşen vidalarının sıkılığını kontrol edin. En ufak bir arızanın meydana gelmesi halinde, derhal ve profesyonel olarak olağan dışı bakım yapmak zorunludur.

DİKKATLİ OLUN

Ürüne uygun olmayan hatalı kullanımlardan sakının. Olası ihlaller veya sağlایıcı yönergelerine uygun olmayan kurulumlar onaylanan ürün uygunluk durumlarını geçersiz kılabilir.

NO) produktinformasjon

produktnavn: **ZNK**
karakteristikk: spiraltrapp med sirkulært plan

produksjonsmaterialer

STRUKTUR

beskrivelse
sammensatt av avstandsholdere (1) i metall (sveiset til trappetrinnet) og avstandsstykker (2) i plast, stablet lagvis og komprimert på modulens midtstolpe (3)
materialer
avstandsholdere: Fe 370
avstandsstykker: nylon 66
stolpe: Fe 370 galvanisert
finish
avstandsholdere: varmgalvanisert

TRAPPETRINN

beskrivelse
sirkelformede trappetrinn (4) i metall, stablet på midtstolpen (3)
materialer
trappetrinn: metalplate Fe 370, tykkelse 25/10
finish
varmgalvanisert

REKKVERK

beskrivelse
sammensatt av loddrette spiler i metall (5) som er festet i trappetrinnene (4), og av en håndløper (6) i PVC
materialer
spiler: Fe 370
håndløper: PVC
fester (7): nylon
finish
spiler: varmgalvanisert

RENGJØRING OG NØDVENDIG VEDLIKEHOLD

Rengjør trappen straks det oppstår flekker eller støvansamlinger. Trappen må dessuten rengjøres jevnlig minst hver 6. måned med en myk klut fuktet med vann og spesielle milde rengjøringsmidler som ikke lager riper. Bruk **IKKE** rengjøringssvamper med slipeeffekt eller stålull. Skyll og tørk omhyggelig med en mikrofiberklut etter rengjøringen, slik at alle kalkholdige vannflekker fjernes. Kontrollere etter ca. 12 måneder fra installasjonen, at skruene i de forskjellige komponentene er korrekt strammet. Så snart man oppdager den minste funksjonsfeil må det utføres et forskriftsmessig ekstraordinært vedlikeholdsinngrep.

FORHOLDSREGLER VED BRUK

Unngå uriktig og uegnet bruk av produktet. Eventuelle endringer eller innstillinger som ikke er i samsvar med produsentens anvisninger vil kunne medføre at de forhåndsdefinerte produktkonformitetene blir ugyldiggjort.

KO)

제품 세부사항

상품명: **ZNK**

유형: 둥근 나선형 계단

사용된 자재

구조

설명

플라스틱 적층 및 중앙 모듈 기둥에 포장 (3) 및 금속 스페이서 (트레드에 용접) (1) 과 스페이서 (2) 로 구성

재료

스페이서: Fe 370

플라스틱 스페이서: 나일론 66

기둥: 아연을 씌운 철 Fe 370

마무리

스페이서: 열연용융아연도금

발판

설명

금속 원형 발판 (4) 을 중앙 기둥 (3) 에 걸쳐짐

재료

발판: 철판 Fe 370 두께 25/10

마무리

열연용융아연도금

난간

설명

발판 (4) 에 고정된 금속 수직으로 구성되어진 난간

동자 (5) 와 PVC 난간 (6) 으로 구성

재료

난간동자: Fe 370

난간: PVC

픽싱즈 (7): 나일론

마무리

난간동자: 열연용융아연도금

청소 및 정비 의무

먼지와 오염물이 발견되면 바로 트레드를 청소해야 하며, 최소 6개월마다 부드러운 천에 마모되지 않고 자극이 없는 세척제와 물을 묻혀 청소하십시오. 거친 수세미를 사용하지 마십시오. 청소한 후에는 초크세사 천으로 표면을 꼼꼼하게 닦아 물 속의 석회석으로 인해 형성되는 침전물을 제거하십시오.

설치 후 대략 12개월 후에 다양한 구성품의 나사를 점검하여 단단히 조여져 있는지 확인하십시오. 가벼운 오작동이 발생해도 즉시 추가 정비를 전문적으로 실시해야 합니다.

사용 주의점

제품과 관계없는 부적절한 사용을 피하세요. 제품 설명을 따르지 않는 부적절한 사용 또는 설치는 제품 동의를 제품 조항을 무효화 합니다.



ZU
D.U.M.
07/2020

Fontanot S.p.A.
Sede legale ed amministrativa
via P. Paolo Pasolini, 6
47853 Cerasolo Ausa
Rimini, Italy

tel. +39.0541.90.61.11
fax. +39.0541.90.61.24
info@fontanot.it
www.fontanot.it
www.arkestairs.com

cod. 067249001

Design: Centro Ricerche Fontanot

Sistema aziendale Fontanot S.p.A.
certificato CSQ ISO-9001

